

CDE/CDB3000

Operation Manual

Positioning Controller
2 A to 210 A



We reserve the right to make technical changes.

The content of our documentation was compiled with the greatest care and attention, and based on the latest information available to us. We should nevertheless point out that this document cannot always be updated in line with ongoing technical developments in our products. Information and specifications may be subject to change at any time. For information on the latest version please refer to www.lt-i.com.



ATTENTION: The device CDE34.010,W,S is currently still a prototype. All technical data related to this device are therefore preliminary!

CDE/CDB3000 Operation Manual



NOTE: The German version is the original of this Operation Manual.

ID no.: 1001.20B.9-00 • Date: 08/2013

Applicable as from software version CDE V3.1 and CDB V3.0.

Sizes (BG)

BG1

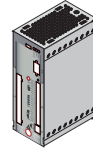

BG2

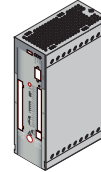

BG3

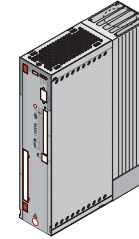

BG4

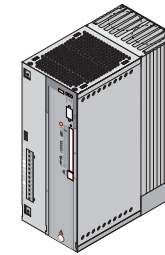

BG5

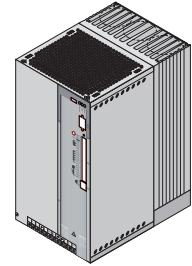

CDE/B 32.003,C
CDE/B 32.004,C

CDB 32.008,C
CDE/B 32.008,W
CDE/B 34.003,C
CDE/B 34.004,W
CDE/B 34.006,W

CDE/B 34.008,W
CDE/B 34.010,W
CDE 34.010,W,S

CDE/B 34.014,W
CDE/B 34.017,W

CDE/B 34.024,W
CDE/B 34.032,W

BG6

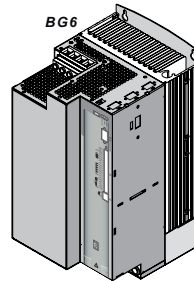

BG7

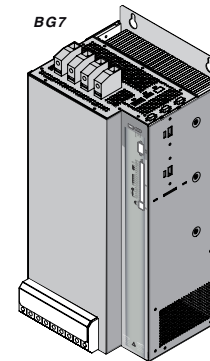

BG7a

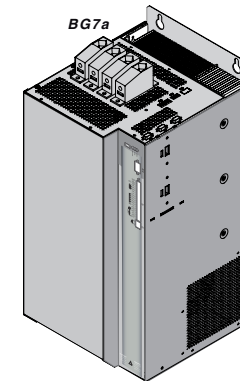

CDE/B 34.044.W / 34.044,L
CDE/B 34.058.W / 34.058,L
CDE/B 34.070.W / 34.070,L

CDE/B 34.088.W / 34.088,L
CDE/B 34.108.W / 34.108,L

CDE/B 34.140.W / 34.140,L
CDE/B 34.168.W / 34.168,L
CDE/B 34.208,L

Table of Contents

1	Safety.....	5
1.1	For your safety.....	5
1.2	Intended use.....	6
1.3	Responsibility.....	6
2	Mechanical installation.....	7
2.1	Notes for operation.....	7
2.2	Wall mounting.....	7
2.3	Cold plate.....	9
2.4	Push-through heat sink.....	9
2.5	Liquid cooling.....	12
3	Electrical installation.....	15
3.1	Overview of connections - CDE.....	15
3.2	Overview of connections - CDB.....	18
3.3	Effective EMC installation - CDE/CDB.....	21
3.4	Protective conductor connection - CDE/CDB.....	22
3.5	Electrical isolation method - CDE/CDB.....	23
3.6	Mains connection - CDE/CDB.....	25
3.6.1	Notes on EN61000-3-2.....	26
3.7	CDE3000.....	27
3.7.1	Control connections - CDE.....	27
3.7.2	CDE encoder connection of LTI motors.....	30
3.7.3	Third-party motor encoder connection to CDE3000.....	32
3.7.4	Motor temperature monitoring - CDE.....	34
3.7.5	Connection of LTI motors.....	34
3.7.6	Connection of third-party motors.....	35
3.8	CDB3000.....	36
3.8.1	Control connections - CDB3000.....	36
3.8.2	Encoder connection - CDB3000.....	40
3.8.3	Motor connection on the CDB3000.....	42
3.8.4	Motor temperature monitoring – CDE.....	43
3.9	Serial interface (SIO) - CDE/CDB3000.....	45
3.10	CAN interface - CDE/CDB3000.....	45
3.11	DC network - CDE/CDB3000.....	46
3.12	Braking resistor (RB) - CDE/CDB3000.....	46
3.13	Safe Torque Off (STO).....	47
4	Commissioning.....	49
4.1	Choice of commissioning.....	49
4.2	Serial commissioning.....	49
4.2.1	Serial commissioning with DriveManager 3.x.....	49
4.3	Initial commissioning.....	50
4.3.1	Preset solutions.....	51
4.3.2	Setting the motor and encoder.....	53
4.3.3	Making basic settings.....	54
4.3.4	Saving the settings.....	55
4.4	Test run.....	56
4.5	Operation with KeyPad KP300.....	58
4.6	Operation with DriveManager 3.x.....	59
5	Diagnosis/Troubleshooting.....	61
5.1	LEDs.....	61
5.2	Error messages.....	61

5.3	User errors in KeyPad operation	62
5.4	User errors in SmartCard operation.....	62
5.5	Errors in power switching.....	63
5.6	Reset	63
A	Appendix.....	65
A.1	Current capacity of positioning controllers.....	65
A.2	Technical data.....	69
A.3	Environmental conditions - CDE/CDB3000.....	71
A.4	Using a line reactor	71
A.5	Mains filters	72
A.6	UL approbation.....	73

Step	Action	Comment
1.	This Operation Manual will enable you to install and start using the CDE3000 and CDB3000 positioning controllers quickly and easily.	Quick-start guide
2.	Simply follow the step-by-step charts set out in sections 2, 3 and 4. Experience „plug'n play“ with the CDE3000 and CDB3000.	

How to use this manual

Contents		
1	Safety	1
2	Mechanical installation	2
3	Electrical Installation	3
4	Commissioning	4
5	Diagnosis/Troubleshooting	5
Appendix:	Technical data, ambient conditions, project planning notes, UL approbation	A

Date of manufacture

On the rating plates of the CDE/CDB drive units you will find the serial number, from which you can identify the date of manufacture based on the following key.

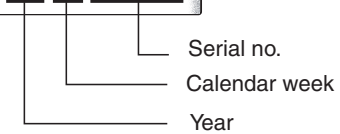
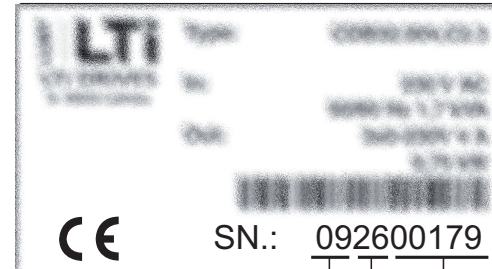

Documentation overview

Document	Order designation	Purpose
CDE/CDB3000 Application Manual	1001.22B.x-xx	Adaptation of the drive system to the application
CANopen Communications Manual	1005.26B.x-xx	Project planning and function description
PROFIBUS-DP Communications Manual	0916.20B.x-xx	Project planning and function description

Pictograms



- Attention! Misoperation may damage the drive or cause it to malfunction.



- Danger from electrical tension! Improper conduct may endanger human life.



- Danger from rotating parts! Drive may start up automatically.



- Note: Useful information

1 Safety

1.1 For your safety

The instructions set out below should be read through prior to initial commissioning in order to prevent injury and/or damage to property.
The safety regulations must be strictly observed at any time.



Read the Operation Manual first!

- Follow the safety instructions!
- Refer to the user information!



Electric drives are dangerous:

- Electrical voltage 230 V/460 V:
Dangerously high voltage may still be present 10 minutes after the power is cut. You should therefore always check that no power is being applied!
- Rotating parts
- Hot surfaces



Protection against magnetic and/or electromagnetic fields during installation and operation.

- Persons fitted with heart pacemakers, metallic implants and hearing aids etc. must not be allowed access to the following areas:
 - Areas where drive systems are installed, repaired and operated.
 - Areas where motors are installed, repaired and operated. Motors with permanent magnets pose a particular hazard.



DANGER: If it is necessary to access such areas, suitability to do so must be determined beforehand by a doctor.



Your qualification:

- In order to prevent personal injury or damage to property, only personnel with electrical engineering qualifications may work on the device.
- The said qualified personnel must be familiar with the contents of the Operation Manual (cf. IEC364, DIN VDE0100).
- Awareness of national accident prevention regulations (e.g. BGV A3 in Germany).





During installation observe the following instructions:

- Always comply with the connection conditions and technical specifications.
- Comply with the standards for electrical installations, such as regarding cable cross-section, PE conductor and ground connections.
- Do not touch electronic components and contacts (electrostatic discharge may destroy components).

Pictograms used

The safety instructions detail the following hazard classes. The hazard class defines the risk posed by failing to comply with the safety notice.

Warning symbols	General explanation	Hazard class to ANSI Z 535
	ATTENTION! Misoperation may damage the drive or cause it to malfunction.	Serious injury or damage to property may occur.
	DANGER FROM ELECTRICAL TENSION! Improper conduct may endanger human life.	Death or serious injury will occur.
	DANGER FROM ROTATING PARTS! Drive may start up automatically.	Death or serious injury will occur.

1.2 Intended use

Drive controllers are components that are intended for installation in stationary electrical systems or machines.

The drive controllers may not be commissioned (i.e. it may not be put to their intended use) until it has been established that the machine complies with the provisions of EC Directive 2006/42/EEC (Machinery Directive); EN 60204 is to be observed.

Commissioning (i.e. putting the device to its intended use) is only permitted in compliance with the EMC Directive (2004/108/EEC).

 The CDE/CDB3000 conforms to the Low Voltage Directive 2006/95/EC.

The harmonized standards of the EN 61800-5-1 series in conjunction with EN 60439-1/VDE 0660 part 500 and EN 60146/VDE 0558 are to be applied with regard to the drive controllers.

If the drive controller is used for special applications (e.g. in areas subject to explosion hazard), the required standards and regulations (e.g. EN 50014, "General provisions" and EN 50018 "Pressurized enclosure") must always be observed.

Repairs may only be carried out by authorized repair workshops. Unauthorized opening and incorrect intervention could lead to death, physical injury or material damage. The warranty provided by LTi DRIVES would thereby be rendered void.



NOTE: Deployment of the drive controllers in non-stationary equipment is classed as operation in non-standard ambient conditions, and is permissible only by special agreement.

1.3 Responsibility

Electronic devices are fundamentally not fail-safe. The company setting up and/or operating the machine or system is itself responsible for ensuring that the drive is rendered safe if the device fails.

EN 60204-1/DIN VDE 0113 "Safety of machines", in the section on "Electrical equipment of machines", stipulates safety requirements for electrical controls. They are intended to protect personnel and machinery, and to maintain the function capability of the machine or system concerned, and must be observed.

The function of an emergency off system does not necessarily have to cut the power supply to the drive. To protect against danger, it may be more beneficial to maintain individual drives in operation or to initiate specific safety sequences. Execution of the emergency off measure is assessed by means of a risk analysis of the machine or system, including the electrical equipment to EN ISO 14121 (formerly DIN EN 1050), and is determined with selection of the circuit category in accordance with EN ISO 13849-1 (formerly DIN EN 954-1) "Safety of machines - Safety-related parts of controls".

2 Mechanical installation

2.1 Notes for operation



Please strictly avoid ...

- penetration of damp into the device,
- aggressive or conductive substances in the immediate vicinity,
- drill chippings, screws or foreign bodies dropping into the device,
- covering over ventilation openings,
- operation of the device in non-stationary equipment, because it may otherwise be damaged..

2.2 Wall mounting

Step	Action	Comment
	Mark out the position of the tapped holes on the backing plate. Cut a tap for each fixing screw in the backing plate	Dimensional drawings/hole spacing see Table 2.1. The tapping area will provide you with good, full-area contact.
	Mount the positioning inverter VERTICALLY on the backing plate.	Pay attention to the mounting clearances! The contact surface must be metallically bright.
	Mount the other components, such as the mains filter, line reactor etc., on the backing plate.	The cable between the mains filter and the inverter must not be longer than max. 30 cm.
	Continue with the electrical installation in chapter 3.	

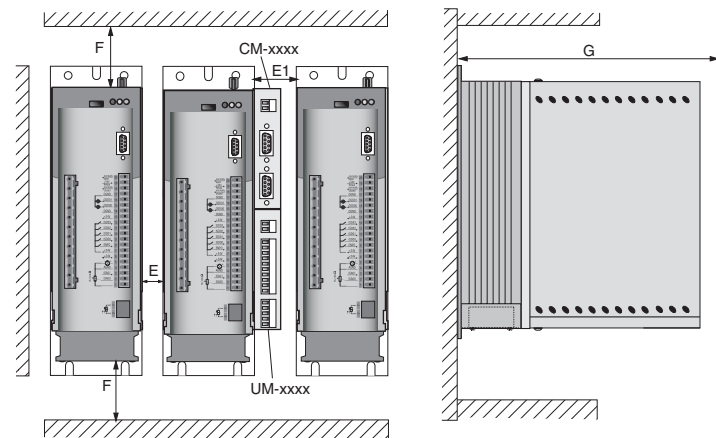

Figure 2.1 Mounting clearances (see Table 2.1)

CDE/CDB3 ...,Wx.x	BG1 ²⁾	BG2 ²⁾	BG2	BG3 BG3S	BG4	BG5	BG6	BG7	BG7a
Weight [kg]	1.6	2.3	3.5	4.4	6.5	7.2	13	28	32
B (width)	70				120	170	190	280	280
H (height) (CDE/ CDB)	220/193	245/218	247/247	300			348	540	540
T (depth)	120	145	220	218			230	267.5	321
A	50		40		80	130	150	200	200
C (CDE/CDB)	230/205	255/230	260	320			365	581	581
DØ	Ø 4.8						Ø 5.6	Ø 9.5	Ø 9.5
Screws	4 x M4						4 x M5	4 x M9	4 x M9
E see Figure 2.1	0	0 ⁴⁾	0				10	10	10
E1 see Figure 2.1				35/50 ¹⁾				35/50 ¹⁾	35/50 ¹⁾
F see Figure 2.1				100 ³⁾				100 ³⁾	100 ³⁾
G see Figure 2.1				≥ 300					≥ 500
J (CDE/CDB)	18/45			45	55	Shield speci- fied	-		
K	215	240	270	330			382	600	

1) 50 mm clearance between the controllers to enable replacement of the side option module (without dismantling the drive controller).

2) Corresponds to cold plate version, see Table 2.2.

3) Additionally allow enough space at the bottom for the bend radii of the connecting cables.

4) End-to-end mounting of CDB32.008, Cx.x not permitted. Please use CDB32.008, Wx.x.

Table 2.1 Dimensional drawings for wall mounting (dimensions in mm)

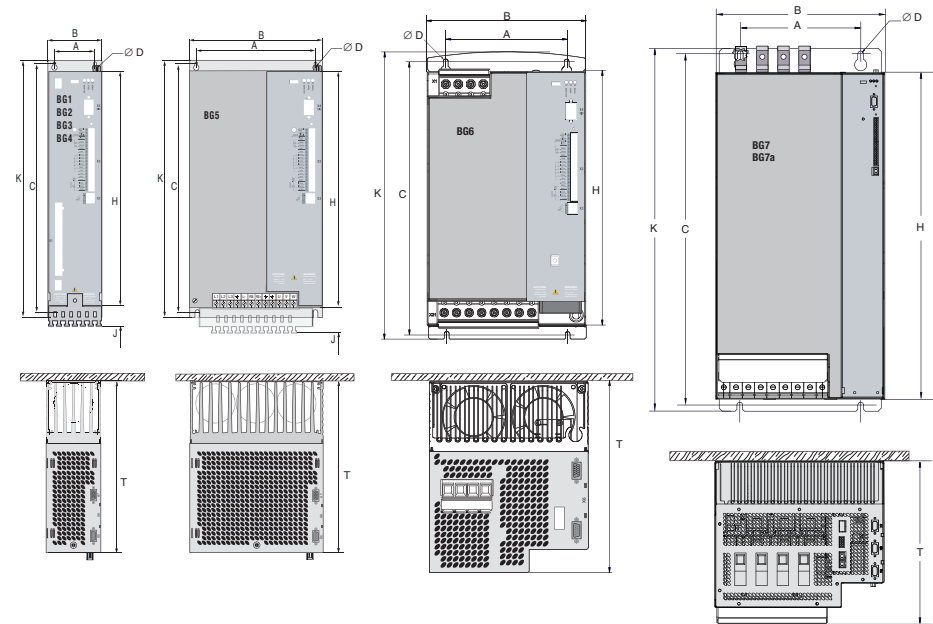

Figure 2.2 Dimensional drawings for wall mounting

2.3 Cold plate

Size	Power	Positioning controller	$R_{th}K^{(1)}$ [K/W]	Backing plate (unvarnished steel) min. cooling area ²⁾
BG1	0.375kW	CDE/CDB32.003, C	0.05	None
	0.75 kW	CDE/CDB32.004, C	0.05	650x100 mm = 0.065 m ²
BG2	1.5 kW	CDE/CDB32.008, C	0.05	650x460 mm = 0.3 m ²
	0.75 kW	CDE/CDB34.003, C	0.05	None

1) Thermal resistance between active cooling area and cooler
2) When mounting end-to-end with no backing plate, use an external heat sink HS3x.xxx or the wallmounted variant.





Table 2.2 Required cooling with cold plate



NOTE THE FOLLOWING POINTS:

- Air must be able to flow unhindered through the device.
- For mounting in switch cabinets with convection (= heat loss is discharged to the outside via the cabinet walls), always fit an internal air circulation fan.
- The backing plate must be well grounded.
- To attain the best result for effective EMC installation use a chromated or galvanized backing plate. If backing plates are varnished, remove the coating from the contact area.
- Size 1 positioning controllers (CDE/CDB32.003 and CDE/CDB32.004) must be mounted on chromated/galvanized switch cabinet backing plates with 0.065 m² cooling area per positioning controller.
- When mounting without additional cooling area (cold plate variant), use heat sink types matching series HS3X.xxx.
- Further information on environmental conditions can be found in appendix A3.

2.4 Push-through heat sink

Step	Action	Comments
	Mark out the positions of the tapped holes and the break-through on the backing plate. Cut a tap for each fixing screw in the backing plate..	Dimensional drawings/hole spacing see Table 2.4. The tapping area will provide you with good, full-area contact.
	Mount the positioning controller vertically on the backing plate. Tighten all screws to the same tightness.	Observe the mounting clearances! The mounting seal must contact flush on the surface.
	Mount the additional components, such as the mains filter, line reactor, etc., on the backing plate.	Mains filter-drive controller connecting cable max. 30 cm
	Continue with the electrical installation in section 3.	



NOTE THE FOLLOWING POINTS:

- Distribution of power loss:

		BG3	BG4	BG5	BG6
Power loss	Outside (3)	70 %	75 %	80 %	80 %
	Inside (4)	30 %	25 %	20 %	20 %
Protection	Heat sink side (3)	IP54	IP54	IP54	IP54
	Machine side (4)	IP20	IP20	IP20	IP20

- The all-round mounting collar must be fitted with a seal. The seal must fit flush on the surface and must not be damaged:

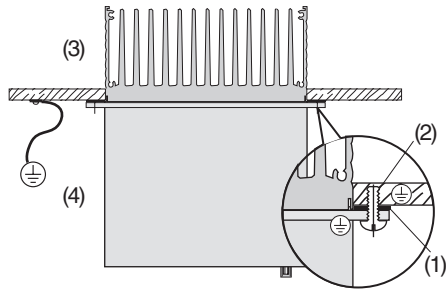

1. Seal
2. Tapped hole for effective EMC contact
3. Outside
4. Inside



NOTE THE FOLLOWING POINTS:

- The backing plate must be well grounded.
- To attain the best result for effective EMC installation use a chromated or galvanized backing plate. If backing plates are varnished, the coating must be removed in the area of the contact surface!

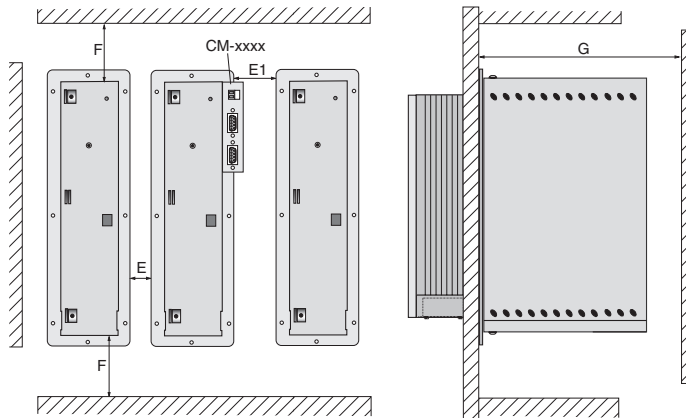

Figure 2.3 Mounting clearances (see Table 2.4)

Dimensions of breakthrough	BG3	BG4	BG5	BG6
B (width)	75	125	175	200
H (height)	305	305	305	355

Table 2.3 Breakthrough for push-through heat sink (dimensions in mm)

CDE/CDB3..., Dx.x	BG3	BG4	BG5	BG6
Weight [kg]	4.6	6.7	7.4	15
B / B1 (width)	70 / 110	120 / 160	170 / 210	190 / 250
H (height)	300			345
T (depth)	138			161 / T1=85
A	90	140	190	236
A1	–	80	100	78
C	320			398
C1	200			*)
DØ	Ø 4.8	Ø 4.8	Ø 4.8	Ø 7.5
Screws	8 x M4	10 x M4	10 x M4	14 x M7
E 2)	10			10
E1 (with module)2)	40			
F 2)	100 ¹⁾			
G 2)	≥ 300			
J	45		55	Shield specified
K	340			405
*) C1=7 / C2=104.75 / C3=202.5 / C4=300.25				
1) Additionally allow enough space at the bottom for the bend radii of the connecting cables.				
2) Dimensions E to G see Figure 2.3				

Table 2.4 Dimensional drawings: push-through heat sink (dimensions in mm)



NOTE: For more information on the ambient conditions see appendix A.3.

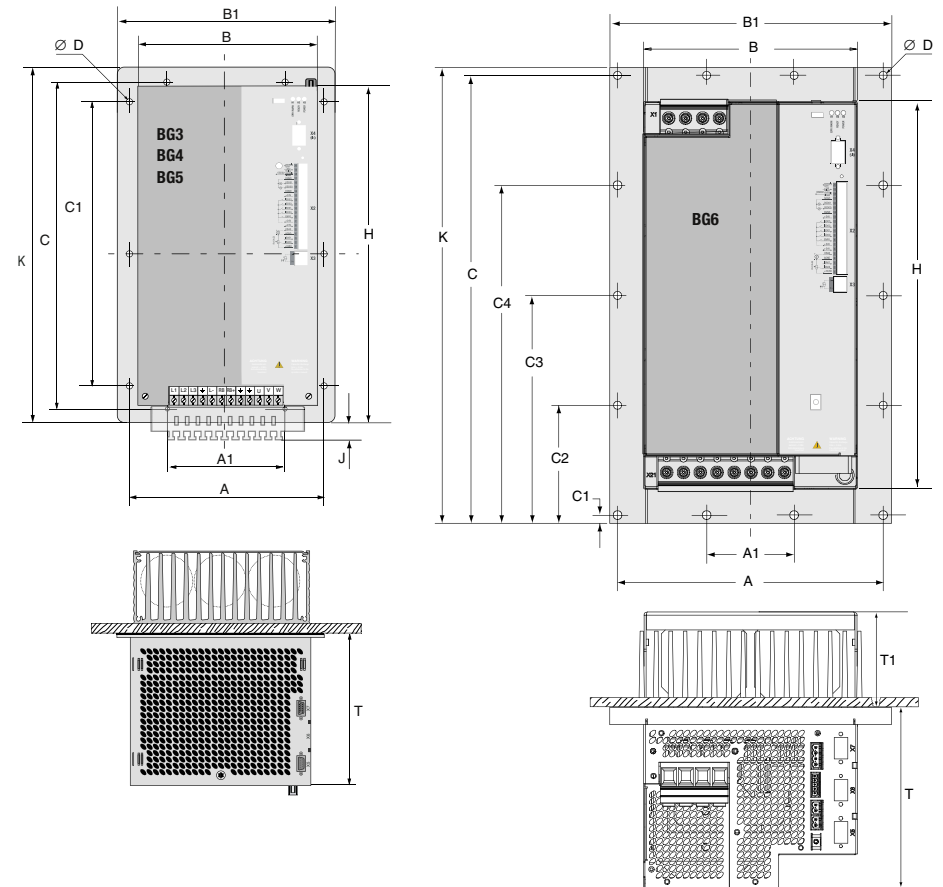

Figure 2.4 Dimensional drawings: push-through heat sink (dimensions in mm)

2.5 Liquid cooling

Step	Action	Comments
1.	Mark out the position of the tapped holes on the backing plate. Cut a tap for each fixing screw in the backing plate.	Dimensional drawings/hole spacing see Table 2.1. The tapping area will provide you with good, full-area contact.
2.	Mount the positioning controller vertically on the backing plate.	Pay attention to the mounting clearances! The contact surface must be metallically bright.
3.	Connect the supply for the liquid cooler.	For details see CDX.X4.XXX,L Specification (ID no.: 181-00945 • 07/2008)
4.	Mount the other components, such as the mains filter, line reactor eetc., on the backing plate.	The cable between the mains filter and the inverter must not be longer than max. 30 cm.
5.	Continue with the electrical installation in chapter 3.	

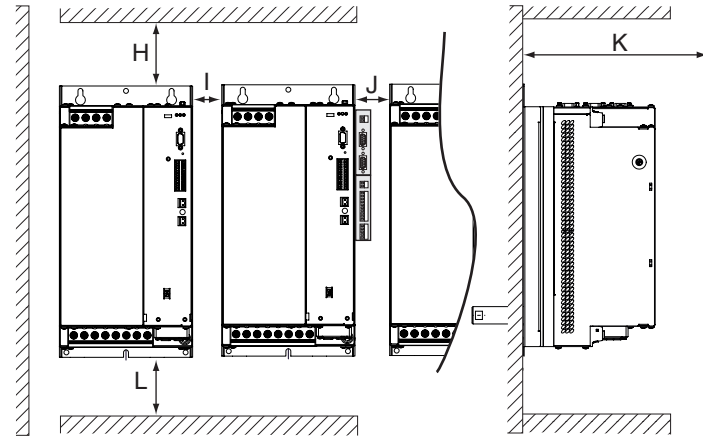

Figure 2.5 Mounting clearances for drive units with liquid cooling

CDE/B...LX.X	BG6	BG7	BG7a
H [mm]	50	50	50
I [mm]	10	10	10
J [mm]	40	40	40
K [mm]	200	240	450
L [mm]	200	200	200

Table 2.5 Mounting clearances for drive units with liquid cooling

CDE/CDB3...,Lx.x	BG6	BG7	BG7a
Weight	15 kg	28 kg	32 kg
Dimensions	BG6 [mm]	BG7 [mm]	BG7a [mm]
B (width)	190	280	280
H (height)	394,75	600	600
T (depth)	190	201	281
A1	148	200	200
A2	148	200	200
C	377.25	581	581
D1 ø	ø 7.0	ø 9.5	ø 9.5
D2 ø	ø15	ø15	ø15
E1	61.75	66.5	66.5
F1	130	175	175
F2	70	70	70
G	73.5	73.5	73.5
S	3/8"	3/8"	3/8"

Table 2.6 Dimensional drawings: liquid cooling (dimensions in mm)

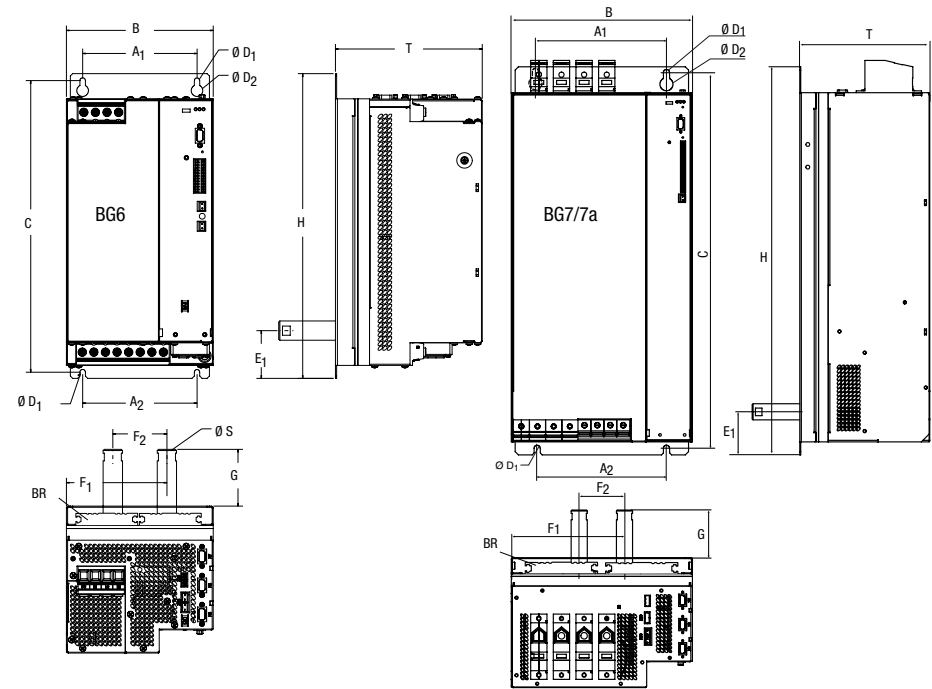

Figure 2.6 Dimensional drawings: liquid cooling

3 Electrical installation

3.1 Overview of connections - CDE



NOTE: Installation must only be carried out by qualified electricians who have undergone instruction in the necessary accident prevention measures.

No.	Page	Designation	Function
H1, H2, H3	page 61	LEDs	Device status display
S1	page 46	DIP switch	Setting the CAN address
X1	page 25 mains page 34 motor	Power connection	Mains, motor, DC feed (L+/L-) Braking resistor L+/RB
	page 22	Protective conductor connection	
X2	page 27	Control connection	STO with relay output 8 digital inputs, 2 analog input, 10 bit 3 digital outputs, 1 relay
X3 ¹⁾	page 34	Motor temperature monitoring (when using encoder interface X7)	PTC, following DIN 44082 Linear temperature encoder KTY 84-130 or Klixon thermostatic circuit-breaker
X4	page 45	RS232 port	For PC with DriveManager 3.x or key-pad KP300 (previously KP200-XL)
X5	page 45	CAN interface	Access to integrated CAN interface CiA 402
X6	page 32	Resolver connection	With temperature monitoring
X7	page 32	TTL/SSI encoder interface	TTL encoder SSI absolute value encoder, optionally: Sin/Cos encoder
X8	page 17	Option slot	Expansion slot e.g. for option module PROFIBUS-DP (CM-DPV1))
X9	page 25	Brake driver	2 A

1) The PTC may only be connected to one of the two termination options X3 or X6.

Table 3.1 Key to connection diagram - CDE3000 BG1 - 5

Connection diagram - CDE3000 (BG1 ... BG5)

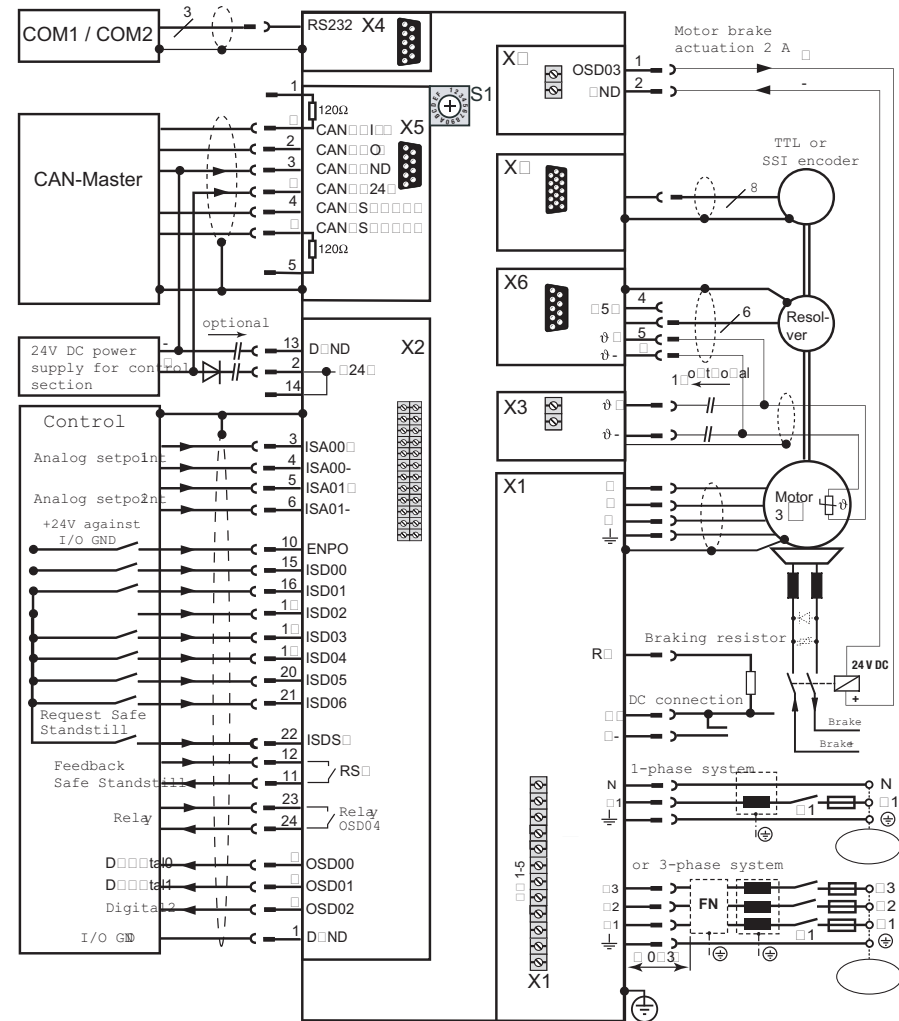
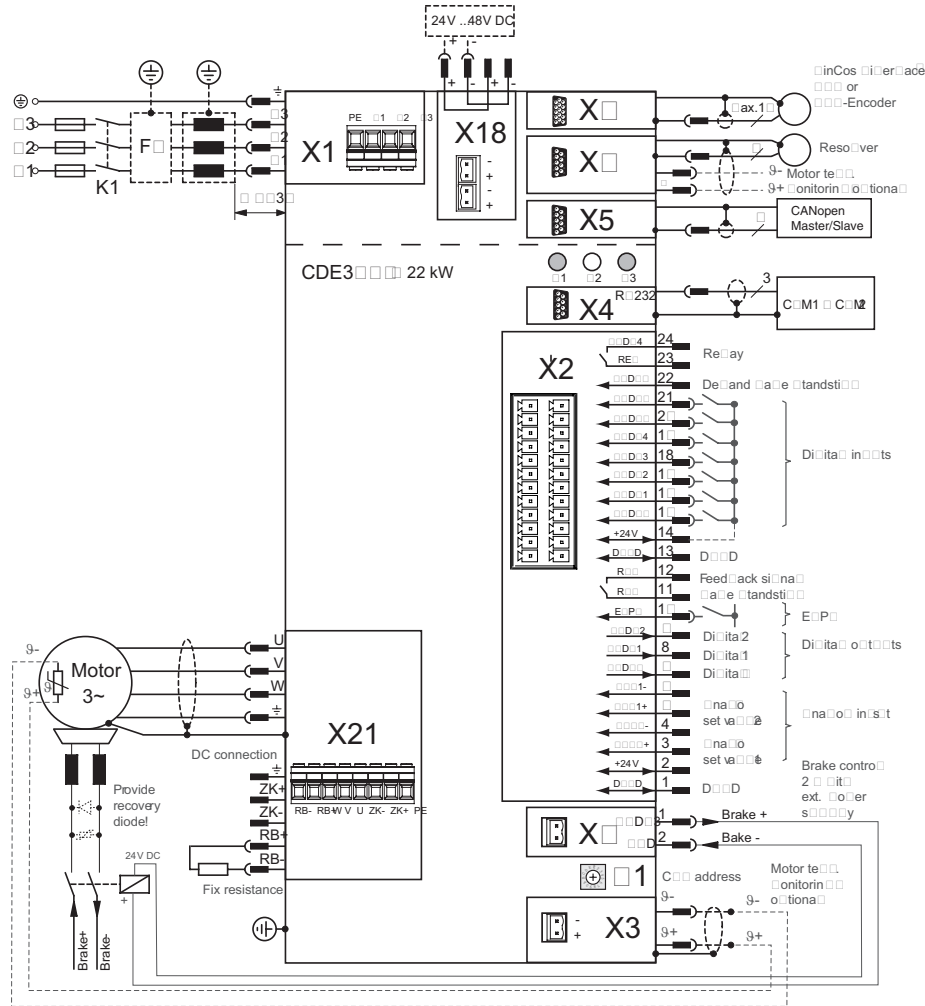

Figure 3.1 Connection diagram - CDE3000 (BG1... BG5)

Connection diagram - CDE3000 (BG6, 7, 7a)



NOTE: Installation must only be carried out by qualified electricians who have undergone instruction in the necessary accident prevention measures.

No.	Page	Designation	Function	
H1, H2, H3	page 61	LEDs	Device status display	
S1	Page 46	DIP switch	Setting the CAN address	
X1	BG6-7	page 25	Mains connection	Mains
X21	BG6-7	page 34	Power connection	Motor, DC feed (ZK+/ZK-) Braking resistor RB+/RB-
⊕	page 22	Protective conductor connection		
X2	page 27	Control connection	STO with relay output 8 digital inputs, 2 analog input, 10 bit 3 digital outputs, 1 relay	
X3 ¹⁾	page 34	Motor temperature monitoring (when using encoder interface X7)	PTC, following DIN 44082 Linear temperature encoder KTY 84-130 or Klaxon thermostatic circuit-breaker	
X4	page 45	RS232 port	For PC with DriveManager 3.x or keypad KP300 (previously KP200-XL)	
X5	page 45	CAN interface	Access to integrated CAN interface CiA 402	
X6	Seite 32	Resolver connection	With temperature monitoring	
X7	page 32	TTL/SSI encoder interface	TTL encoder SSI absolute value encoder, optionally: Sin/Cos encoder	
X8	page 17	Option slot	Expansion slot e.g. for option module PROFIBUS-DP (CM-DPV1)	
X9	page 25	Brake driver	2 A	
X18		External controller voltage supply	24V -25 % bis 48 V +10 % DC (required as from U _{ZK} < 200 V)	
X19	X20	-	-	No function

¹⁾ The PTC may only be connected to one of the two termination options X3 or X6.

Table 3.2 Key to connection diagram - CDE3000 (BG6, 7, 7a)

Figure 3.2 Connection diagram - CDE3000 (BG6, 7, 7a)

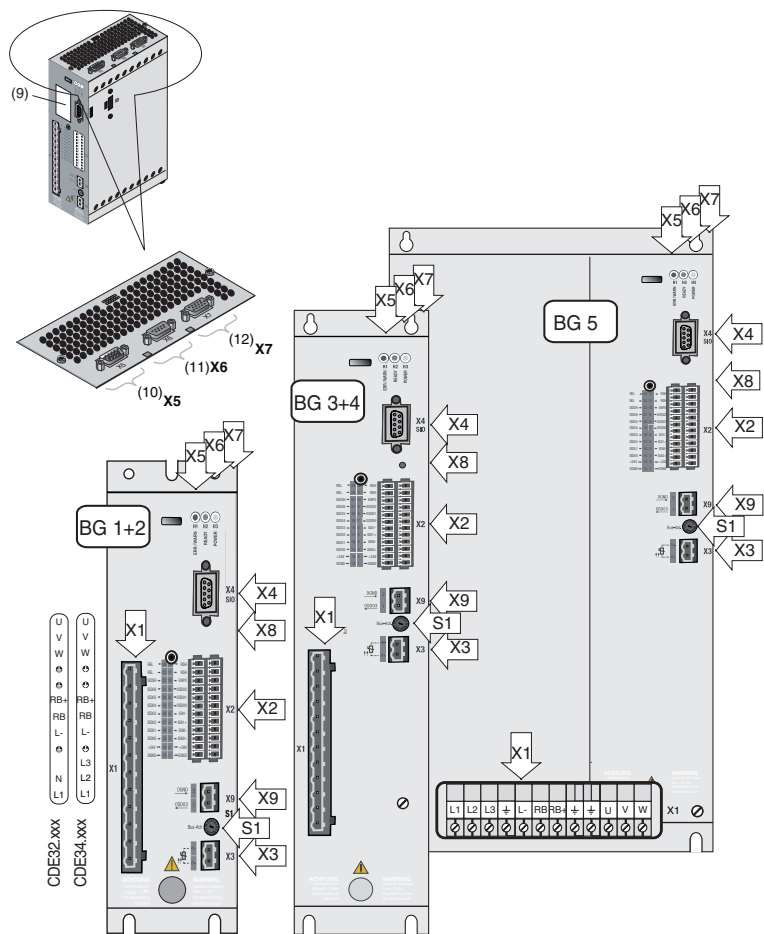

Figure 3.3 Layout of CDE3000 (BG1 to BG5)

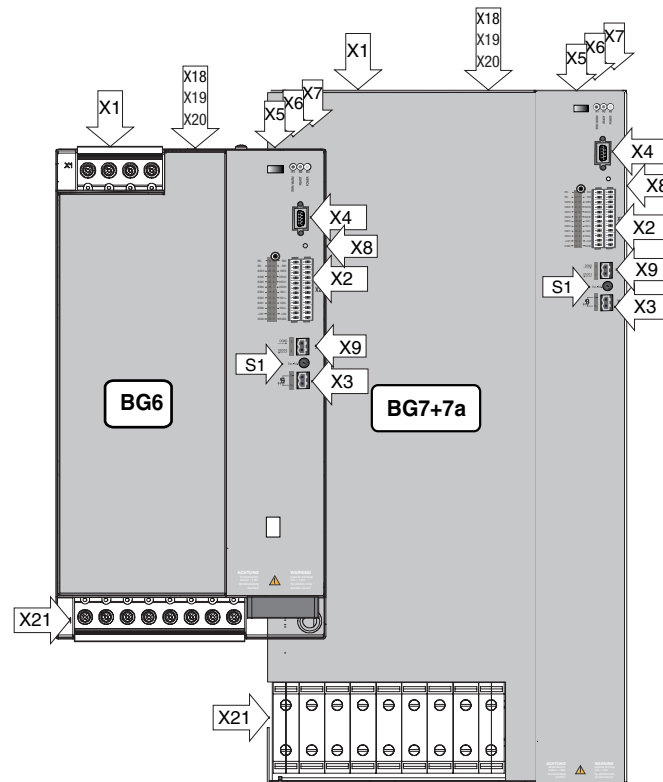

Figure 3.4 Layout of CDE3000 (BG6, BG7 and BG7a)

3.2 Overview of connections - CDB

Connection diagram - CDB3000 (BG1 ... BG5)

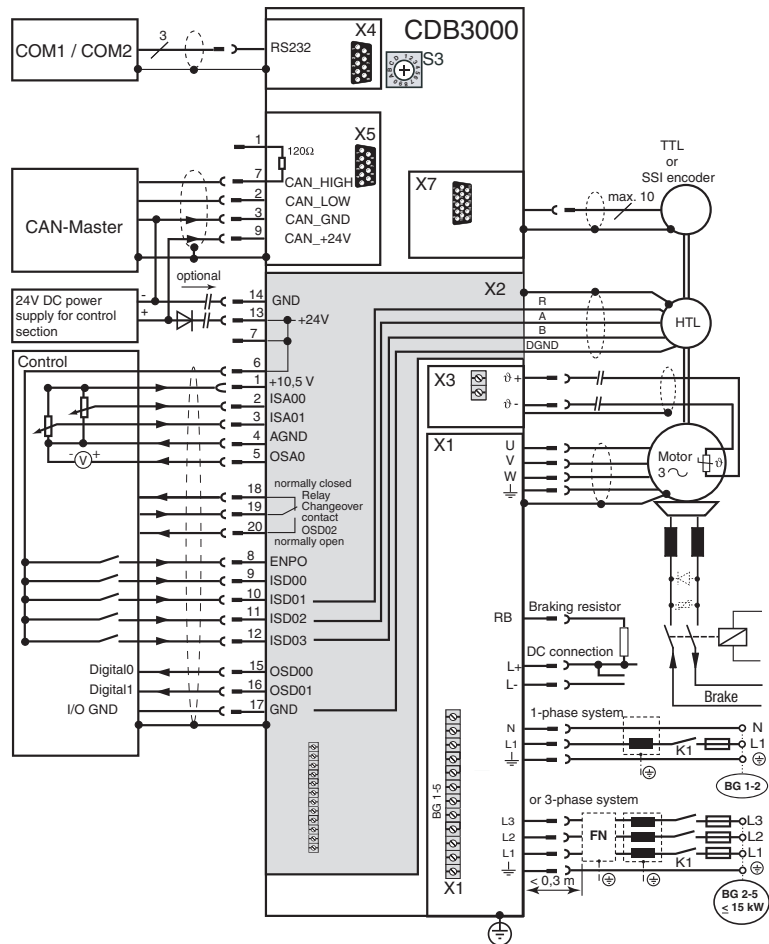

Figure 3.5 Connection diagram - CDB3000 (BG1 ...BG5)



NOTE: Installation must only be carried out by qualified electricians who have undergone instruction in the necessary accident prevention measures.

No.	Page	Designation	Function
H1, H2, H3	page 61	LEDs	Device status display
S3	page 46	DIP switch	Setting the CAN address
X1	page 25 mains page 42 motor	Power connection	Mains, motor, DC feed (L+/L-) Braking resistor L+/RB
⚡	page 22s	Protective conductor connection	
X2	page 36	Control connection	5 digital inputs, 2 analog inputs, STO function only in CDB3000 version SH 2 digital outputs, 1 relay, 1 analog output
X3	page 43	Motor temperature monitoring (when using encoder interface X7))	PTC, following DIN 44082 Linear temperature encoder KTY 84-130 or Klixon thermostatic circuit-breaker
X4	page 45	RS232 port	For PC with DriveManager 3.x or keypad KP300 (previously KP200-XL)
X5	page 45	CAN interface	Access to integrated CAN interface CiA 402
X7	page 40	TTL/SSI encoder interface	TTL encoder SSI absolute encoder
X8	-	Option slot	Expansion slot e.g. for option module Profibus-DP (UM-DPV1)

Table 3.3 Key to connection diagram - CDB3000 (BG1 - 5)

Connection diagram - CDB3000 (BG6, 7, 7a)

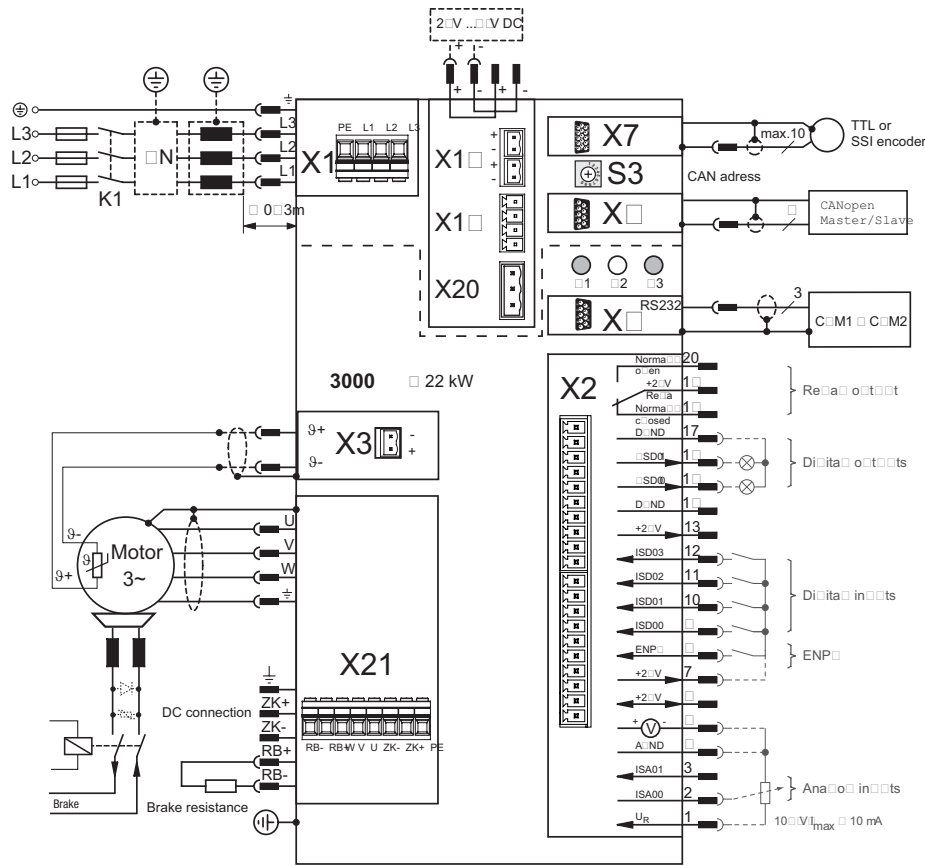

Figure 3.6 Connection diagram - CDB3000 (BG6, 7, 7a)



NOTE: Installation must only be carried out by qualified electricians who have undergone instruction in the necessary accident prevention measures.

No.	Page	Designation	Function
H1, H2, H3	page 61	LEDs	Device status display
S3	page 46	DIP switch	Setting the CAN address
X1	BG6-7 page 25	Mains connection	Mains
X21	BG6-7 page 42	Power connection	Motor, DC feed (ZK+/ZK-) Braking resistor RB+/RB-
⊕	page 22	Protective conductor connection	
X2	page 36	Control connection	5 digital inputs, 2 analog inputs, STO function only in CDB3000 version SH 2 digital outputs, 1 relay, 1 analog output
X3	page 43	Motor temperature monitoring (when using encoder interface X7)	PTC, following DIN 44082 Linear temperature encoder KTY 84-130 or Klixon thermostatic circuit-breaker
X4	page 45	RS232 port	For PC with DriveManager 3.x or keypad KP300 (previously KP200-XL)
X5	page 45	CAN interface	Access to integrated CAN interface CiA 402
X7	page 40	TTL/SSI encoder interface	TTL encoder SSI absolute encoder
X8	-	Option slot	Expansion slot e.g. for option module Profibus-DP (UM-DPV1)
X18	-	External controller voltage supply	24V -25 % bis 48 V +10 % DC (required as from $U_{ZK} < 200$ V)
X19	X20	-	No function

Table 3.4 Key to connection diagram - CDB3000 (BG6, 7, 7a)

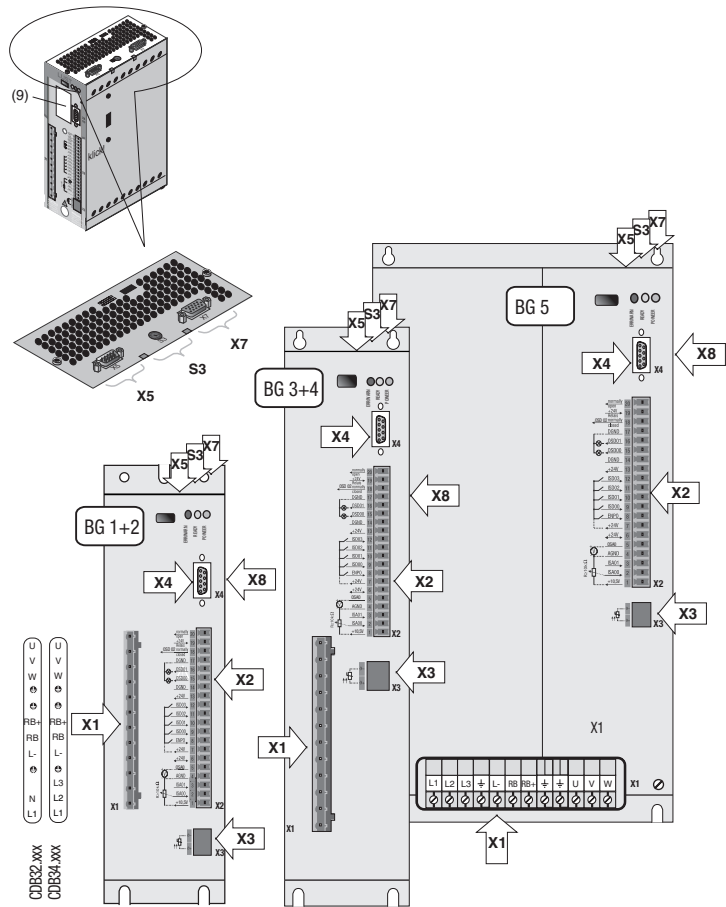

Figure 3.7 Layout of CDB3000 (BG1 to 5)

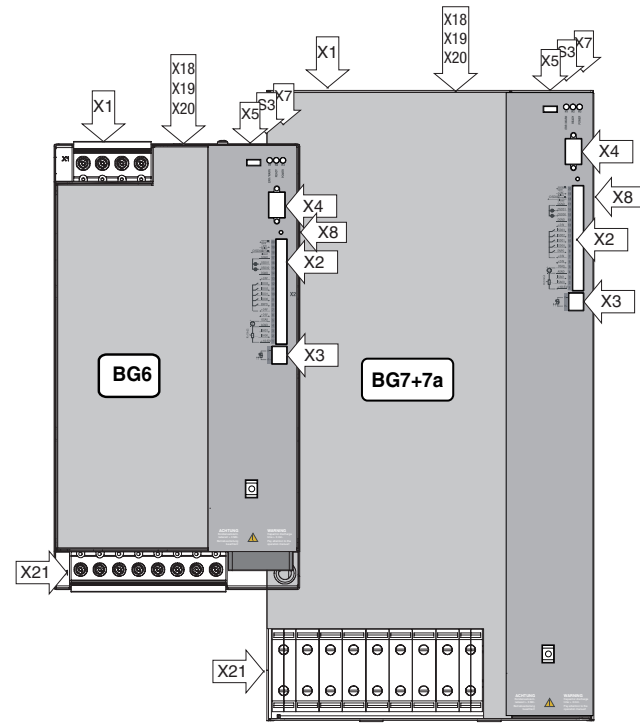

Figure 3.8 Layout of CDB3000 (BG6, 7 and 7a)

3.3 Effective EMC installation - CDE/CDB

Positioning inverters are components intended for installation in industrially and commercial plant and machinery.

Commissioning (i.e. putting the device to its intended use) is only permitted in compliance with the EMC Directive (2004/108/EC).

Verification of conformance to the safety targets laid down in the EMC Directive must be provided by the company installing/operating a machine and/or system.



ATTENTION: If the installation instructions set out in this Operation Manual are followed, and the appropriate RFI filters are used, conformance to the stipulated EMC safety targets is normally achieved.

Assignment of drive controller with internal mains filter

All CDE/CDB drive controllers have a sheet steel housing with an aluminium/zinc finish to enhance interference immunity to IEC61800-3, environments 1 and 2.

The drive controllers 0.37 kW to 7.5 kW and 22 kW to 37 kW are fitted with integral mains filters. Based on the measurement method stipulated by the standard, the drive controllers conform to the EMC product standard EN 61800-3 for the "first environment" (residential) and "second environment" (industrial).

- Public low-voltage network (first environment), residential: up to 10 metres motor cable length; for detailed data see appendix A.5.



ATTENTION: This is a restricted availability product in accordance with IEC 61800-3. This product may cause radio interference in domestic environments; in such cases the operator may need to take appropriate countermeasures.

- Industrial low-voltage network (second environment), industrial: up to 25 metres motor cable length; for detailed data see appendix A.5.

Assignment of drive controller with external mains filter

For all drive controllers an external radio frequency interference (RFI) suppression filter (EMCxxx) is available. With this mains filter the drive controllers conform to the EMC product standard EN 61800-3 for the "first environment" (residential) and "second environment" (industrial).

- Public low-voltage network (first environment), residential: up to 100 metres motor cable length.



ATTENTION: This is a restricted availability product in accordance with IEC 61800-3. This product may cause radio interference in domestic environments; in such cases the operator may need to take appropriate countermeasures.

- Industrial low-voltage network (second environment), industrial: up to 150 metres motor cable length.



NOTE: Use of external mains filters also enables "general availability" to be attained with shorter motor cable lengths. If this is important to you, talk to our sales engineers or your project engineer.



Subject	Project planning and installation rules
PE conductor connection Equipotential bonding	<p>Use a bright backing plate. Use cables and/or ground straps with cross sections as large as possible. Route protective conductors of components in star configuration. To create a low-resistance HF connection both the ground (PE) and shield connection must have large-area contact to the PE rail on the backing plate. PE mains connection according to DIN VDE 0100 part 540</p> <ul style="list-style-type: none"> • Mains connection < 10 mm²/Cu: Use protective conductor cross-section min. 10 mm² or two cables with cross-section of mains power cables. • Mains connection ≥ 10 mm²/Cu: Use a protective conductor cross-section in compliance with the cross-section of the mains supply lines.
Routing of cables	<ul style="list-style-type: none"> • As far as possible, route the motor cable separated from signal and mains supply lines. • Always route the motor cable without interruptions and by the shortest route out of the switch cabinet. • If a motor contactor or motor choke/filter is used, it should be placed directly on the drive controller. Do not bare the shield of the motor cable too early. • Avoid unnecessary cable lengths.
Cable type	<p>The drive controllers must always be wired with shielded motor cables and signal lines. A cable type with double copper braiding with 60-70% coverage must be used for all shielded connections.</p>

Subject	Project planning and installation rules
Further hints for the control cabinet design	<ul style="list-style-type: none"> • Contactors, relays, solenoid valves (switched inductors) must be wired with fuses. The wiring must be directly connected to the respective coil. • Switched inductors should be at least 20 cm away from process controlled assemblies. • Place larger consumers near the supply. • If possible enter signal lines only from one side. • Lines of the same electric circuit must be twisted. Crosstalk is generally reduced by routing cables in close vicinity to grounded plates. Connect residual strands at both ends with the switch cabinet chassis (ground).
Supplementary information	Supplementary information can be found in the relevant connection description.

Table 3.5 Project planning and installation rules

3.4 Protective conductor connection - CDE/CDB

As the leakage current is > 3.5 mA, it is imperative the requirements on the PE connection described in the following are followed.

Step	Action	Note: PE mains connection according to EN61800-5-1
	Ground every positioning controller! Connect terminal X1  to the PE rail (main ground) in the switch cabinet.	Mains connection < 10 mm²/Cu: Use protective conductor cross-section min. 10 mm ² or use 2 cables with cross-section of mains cables.
	Also connect the protective conductor terminals of all other components, such as line reactors, filters etc. in a star configuration to the PE rail (main ground) in the switch cabinet.	Mains connection ≥ 10 mm²/Cu: Use a protective conductor cross-section in compliance with the cross-section of the mains supply lines.

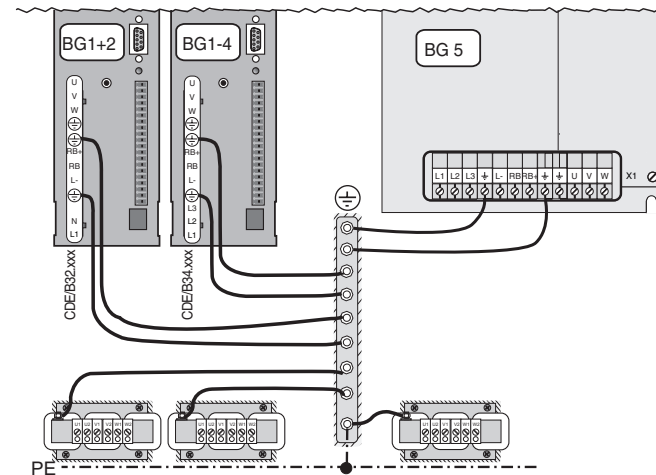

Figure 3.9 Star configuration layout of the protective conductor (BG1-5)



NOTE THE FOLLOWING POINTS:

- The protective conductor must be laid out in star configuration to conform to the EMC standards.
- The backing plate must be well grounded.
- The motor, mains power and control cables must be laid separately from each other.
- Avoid loops, and lay cable over short distances.
- The operational leakage current is > 3.5 mA.

3.5 Electrical isolation method - CDE/CDB

The control electronics with its logic, inputs and outputs is electrically isolated from the DC link direct voltage by means of a two-stage power supply unit.

1. The first stage (SNT1) converts the DC link voltage to a 24 V voltage. This, firstly, supplies the secondary, or input or output, sides of the digital inputs and outputs. It can be externally boosted to increase current capacity. This is necessary whenever the 24 V is subjected to a current load greater than 100 mA (e.g. due to motor holding brake connected to OSD03 on the CDE3000).
2. Secondly, this 24 V voltage feeds into a second power supply unit (SNT2), in which the voltages for the microcontroller, the encoder interfaces, the primary side of the CANopen interface and the analog inputs are generated on the basis of the same potential. The analog ground serves as reference potential for the specification of the analog setpoint.

Thus the digital inputs and outputs supplied from the voltage under 1.) are electrically isolated from 2.). This isolates the processor and the analog signal processing from interference.

The internal CANopen interface inside the device is electrically isolated from the control electronics. The 24 V voltage supply for the secondary side/interface to the application is fed from an external source via connector X5.

Expansion modules such as the I/O terminal expansion module UM-8I4O or the PRO-FIBUS-DP module CM-DPV1 are likewise electrically isolated from the base unit. The module's interface to the application is fed from an external source via a 24 V connection on the expansion module.

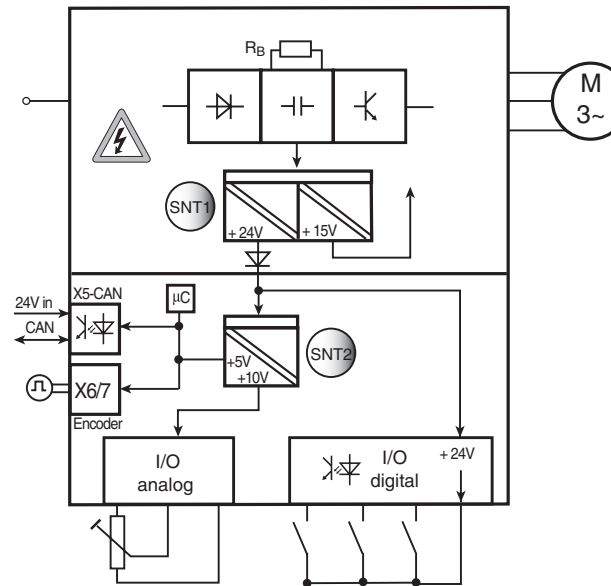

Figure 3.10 Electrical isolation method/voltage supply to the CDE3000/CDB3000

When choosing the cables please bear in mind that the cables for analog inputs and outputs must in any case be shielded. In the case of pair-shielded cables, the cable or single wire shield should extend across as wide an area as possible, for EMC purposes. High frequency disturbance voltages are thus reliably discharged (Skin effect). An EMC-compatible wiring is mandatory and must be strictly assured.

Special case: Use of the analog inputs as digital inputs



NOTE: The analog inputs must either be both used only with analog or both with digital function. Mixing the analog inputs with one input with analog function and another input with digital function is not permitted.

The use of the equipment internal 24 V DC as supply voltage while utilizing an analog input with the function "digital input" requires the connection of analog and digital ground. For the reasons described above this can cause disturbances and requires extreme care when selecting and connecting the control lines.

Safe operation based on the burst resistance to EN 61000-4-4 is not affected by the connection of analog and digital grounds. To minimize the parasitic currents affecting the ground connection, both the analog (AGND) and the digital ground (DGND) must be connected via a VHF reactor (820 μH, 0.5 A, e. g. EPCOS B82500-C-A5, wired).

A jumper is only required when the internal 24 V is used.

X2	Function
1	Reference voltage 10 V, 10 mA
2	ISA00, as dig. input
3	ISA01, as dig. input
4	Analog ground
5	OSA00
6	Auxiliary voltage 24 V, max. 200 mA
7	
13	Auxiliary voltage 24 V
14	Digital ground
15	OSD00
16	OSD01
17	Digital ground

Figure 3.11 Disabling electrical isolation when using the analog inputs with digital function on the CDB3000

A jumper is only required when the internal 24 V is used.

X2	Function
1	Digital ground DGND
2	Auxiliary voltage UV=24 V DC
3	Analog input ISA0+
4	Analog input ISA0-
5	Analog input ISA1+
6	Analog input ISA1-

Figure 3.12 Disabling electrical isolation when using the analog inputs with digital function on the CDE3000



ATTENTION: The ground connection or routing into the system must not be made via the analog ground (terminal 4 on the CDB3000, terminals 4/6 on the CDE3000). It may only be connected via one of the DGND terminals (see Figure 3.13).

Example: Risk of interference

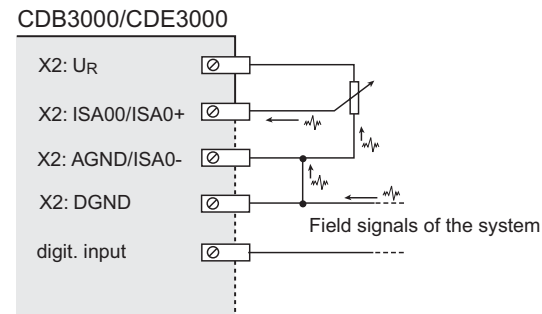







Figure 3.13 Interference on the analog input in the event of defective wiring



NOTE: If more digital inputs and outputs are required than are available on the positioning controllers, we recommend using terminal expansion module UM-8140 with 8 digital inputs and 4 digital outputs.

3.6 Mains connection - CDE/CDB

Step	Action	Comment
 1.	Define cable cross-section depending on maximum current and ambient temperature.	Cable cross-section according to local and national regulations and conditions.
 2.	Wire the drive controller with the mains filter , distance between filter housing and drive controller max. 0.3 m!	Step not applicable for BG1 to BG4; up to 7.5 kW the mains filter is built-in.
 3.	Wire the line reactor see appendix A.5 For BG 6-7 max. 0.3 m distance between reactor housing and drive controller!	Reduces the voltage distortions (THD) in the system and prolongs service life.
 4.	Install a circuit-breaker K1 (power switch, contactor, etc.).	Do not switch on the power!
 5.	Use mains fuses (Utilisation category gG) to cut the mains power to all poles of the drive controller.	To protect the line in accordance with VDE636, part 1

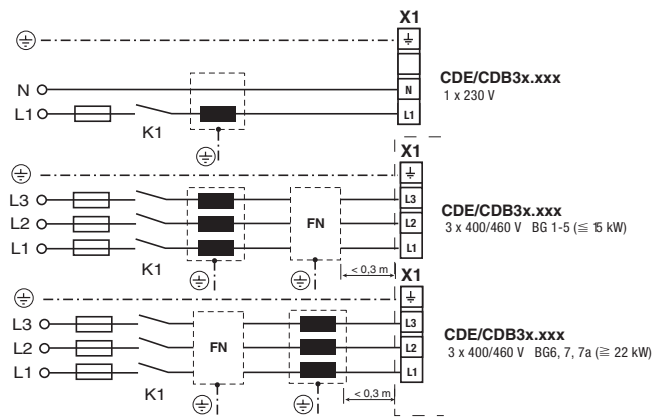

Figure 3.14 Mains connection



ATTENTION: For BG6, BG7/7a size devices a line reactor is essential. Because of the precharging technology of those devices, it must be ensured that the line reactor is installed between the drive controller and the mains filter, otherwise the mains filter may be damaged.
Using the line reactor, see appendix A.4



ATTENTION: Danger to life! Never wire or disconnect electrical connections while these are live. Always disconnect the power before working on the device. Wait until the DC-link voltage at terminals X1/L+ and L- (BG 1-5) or X21/ZK+, ZK- (BG 6, 7, 7a) has fallen to the safety-low voltage before working on the device (approx. 10 minutes).



ATTENTION:

- If local regulations make it necessary to provide an earth leakage trip, the following applies:

Residual current compatibility: In the event of a fault the drive controller may generate DC fault currents with no zero crossing. For this reason drive controllers are only allowed to be operated with residual current devices (RCDs) of type B for AC fault currents, pulsating and smooth DC fault currents that are suitable for use with a drive controller, see IEC 60755. In addition, it is also possible to use residual current monitors (RCMs) for monitoring tasks.

- Switching the mains power: Cyclic power switching is permitted every 60 seconds; jog mode with mains contactor is not permitted.
 - If switching is too frequent, the device protects itself by means of high-resistance isolation from the system.
 - After a rest phase of a few minutes the device is ready to start once again.
- TN and TT network: Operation is permitted if:
 - in the case of single-phase devices for 1 x 230 V AC the supply system conforms to the maximum overvoltage category III as per EN 61800-5-1;
 - in the case of three-phase devices with external conductor voltages 3 x 400 V AC, 3 x 460 V AC
 1. the neutral point of the supply system is grounded and

2. the supply system conforms to the maximum overvoltage category III as per EN 61800-5-1 at a system voltage (external conductor -> neutral point) of maximum 265 V.

- IT network: not permitted!
 - In the event of a ground fault the voltage stress is around twice as high, and creepages and clearances to EN50178 are no longer maintained.
- Connection of the positioning inverter by way of a line reactor with short-circuit voltage UK = 4 % (BG1 to 5) and UK = 2 % (BG6,7,7a) of the rated voltage is essential:
 - where the positioning inverter is used in applications with disturbance variables corresponding to environment class 3, as per EN 61000-2-4 and higher (hostile industrial environment).
 - for compliance with EN61800-3 or IEC 1800-3, see appendix A5.
 - where there is a DC link between multiple drive controllers.
- For more information on current capacity, technical data and environmental conditions refer to appendices A.1 to A.3.

Using the line reactor, see appendix A.4



ENVIRONMENT CLASS 3 TO EN 61000-2-4

Characteristics of environment class 3 include:

- Mains voltage fluctuations > + 10% UN
- Short-time interruptions between 10 ms and 60 s
- Voltage asymmetry between the phases > 3 %

Environment class 3 typically applies where:

- a major part of the load is supplied by power converters
- (DC choppers or soft-start equipment);
- welding machines are in use;
- induction or arc furnaces are in use;
- large motors are started frequently;
- current loads fluctuate rapidly.

Drive controller	Device connected load with line reactor (4 % UK) [kVA]	Without line reactor [kVA]	Max. cable cross-section of terminals [mm ²] ¹⁾	Mains fuse (gG) [A]
CDE/CDB32.004	1.7	1.96	2.5	1 x 10
CDE/CDB32.006	2.3	2.7	2.5	1 x 16
CDE/CDB32.008	3.0	3.5		1 x 16
CDE/CDB34.003	1.5	2.1		3 x 10
CDE/CDB34.005	2.8	3.9		3 x 10
CDE/CDB34.006	3.9	5.4	2.5	3 x 10
CDE/CDB34.008	5.4	7.3	2.5	3 x 10
CDE/CDB34.010	6.9	9.4	2.5	3 x 16
CDE34.010.W.S	6.9	9.4	4.0	3 x 32
CDE/CDB34.014	9.7	13.1	4.0	3 x 20
CDE/CDB34.017	11.8	15.9		3 x 25
CDE/CDB34.024	16.6	22.5	16	3 x 35
CDE/CDB34.032	22.2	30.0		3 x 50
CDE/CDB34.044	31	-	25	3 x 63
CDE/CDB34.058	42	-		3 x 80
CDE/CDB34.070	50	-		3 x 100
CDE/CDB34.088	62	-	50	3 x 125
CDE/CDB34.108	76	-		3 x 160
CDE/CDB34.140	99	-	95	3 x 200
CDE/CDB34.168	118	-		3 x 224
CDE/CDB34.208	128	-		3 x 250

¹⁾ The minimum cross-section of the mains power cable depends on the local regulations and conditions.

Table 3.6 Cable cross-sections and mains fuses

3.6.1 Notes on EN61000-3-2







Limits for harmonic Current emissions

Our positioning controllers and servocontrollers are “professional devices” in the sense of the European Standard EN 61000, and with a rated power of £ 1kW obtained in the scope of this standard.

In case our drive units are used as a component of a machinery/plant, so the appropriate scope of the standard of the machinery/plant must be checked.

3.7 CDE3000

3.7.1 Control connections - CDE

Step	Action	Comment
 1.	Check whether you already have a Smart-Card or a DriveManager 3.x data set with a complete device setup, i.e. the drive has already been planned as required.	
 2.	If this is the case, a special control terminal assignment applies. Please contact your project engineer to obtain the terminal assignment!	Bulk customers For details of how to load the data set into the positioning controller refer to section 4.2.
 3.	Choose a terminal assignment.	Initial commissioning There are various preset solutions available to make it easier to commission the device.
 4.	Wire the control terminals with shielded cables. Essential requirements: STO X2.22 ENPO X2.10 and a start signal (with control via terminal).	Earth the cable shields over a wide area at both ends. Cable cross-section maximum 1.5 mm ² or two strands per terminal at 0.5 mm ²
 5.	Keep all contacts open (inputs inactive).	
 6.	Check all connections again!	Continue with commissioning in chapter 4.



NOTE THE FOLLOWING POINTS:

- Always wire the control terminals with shielded cables.
- Lay the control cables separately from the mains power and motor cables.

- The CDE/CDB3000 Application Manual presents more preset drive solutions.
- A cable type with double copper braiding with 60 - 70 % coverage must be used for all shielded connections.

Specification of control connections - CDE

Des.	Terminal	Specification	Electrical isolation	Control terminal	
Analog inputs					
ISA0+ ISA0- ISA1+ ISA1-	X2-3 X2-4 X2-5 X2-6	<ul style="list-style-type: none"> $U_{IN} = \pm 10$ V DC; Resolution 10 Bit; $R_{IN} = 110$ kΩ Terminal scanning cycle = 1 ms Tolerance: U: ± 1 % v. of measuring range end value 	Yes, against DGND		
Digital inputs					
ISD00 ISD01 ISD02 ISD03 ISD04 ISD05	X2-15 X2-16 X2-17 X2-18 X2-19 X2-20	<ul style="list-style-type: none"> Frequency range < 500 Hz Terminal scanning cycle = 1 ms Switching level Low/High: <4.8 V / >18 V at 24 V typ. 3 mA $R_{IN} = 3$ kΩ 	Yes	X2 REL ← 24 12 → RSH REL → 23 11 ← RSH ISDSH → 22 10 ← ENPO ISD06 → 21 9 → OSD02 ISD05 → 20 8 → OSD01 ISD04 → 19 7 → OSD00 ISD03 → 18 6 ← ISA1- ISD02 → 17 5 ← ISA1+ ISD01 → 16 4 ← ISA0- ISD00 → 15 3 ← ISA0+ +24V ↔ 14 2 ↔ +24V DGND ↔ 13 1 ↔ DGND	
ISD06	X2-21	<ul style="list-style-type: none"> Frequency range < 500 Hz Switching level Low/High: <4.8 V / >18 V I_{max} at 24 V = 10 mA $R_{IN} = 3$ kΩ internal signal delay time < 2 μs suitable as trigger input for quick saving of the actual position 	Yes		
ENPO	X2-10	<ul style="list-style-type: none"> Power stage enable = High level Frequency range < 500 Hz Reaction time approx. 10 ms Switching level Low/High: <4.8 V / >18 V at 24 V typ. 3 mA $R_{IN} = 3$ kΩ 	Yes		
Digital outputs					
OSD00 OSD01 OSD02	X2-7 X2-8 X2-9	<ul style="list-style-type: none"> Short-circuit proof $I_{max} = 50$ mA, PLC compatible Terminal scanning cycle = 1ms High-side driver 	Yes		

Des.	Terminal	Specification	Electrical isolation	Control terminal	
STO					
For more information see section 3.13: Safe Torque Off (STO)					
ISDSH	X2-22	<ul style="list-style-type: none"> STO input Frequency range < 500 Hz Terminal scanning cycle = 1 ms Switching level Low/High: < 4.8 V / >18 V at 24 V typ. 3 mA $R_{IN} = 3$ kΩ 	Yes	X2 REL ← 24 12 → RSH REL → 23 11 ← RSH ISDSH → 22 10 ← ENPO ISD06 → 21 9 → OSD02 ISD05 → 20 8 → OSD01 ISD04 → 19 7 → OSD00 ISD03 → 18 6 ← ISA1- ISD02 → 17 5 ← ISA1+ ISD01 → 16 4 ← ISA0- ISD00 → 15 3 ← ISA0+ +24V ↔ 14 2 ↔ +24V DGND ↔ 13 1 ↔ DGND	
RSH RSH	X2-11 X2-12	<ul style="list-style-type: none"> Relay RSH with STO, function, one NO contact with self-resetting circuit breaker (polyswitch) 25 V / 200 mA AC, $\cos \varphi = 1$ 30 V / 200 mA DC, $\cos \varphi = 1$ 	Yes		
Relay output					
REL REL	X2-23 X2-24	<ul style="list-style-type: none"> Relay, 1 NO contact 25 V / 1 A AC, usage category AC1 30 V / 1 A DC, usage category DC1 Operating delay approx. 10 ms Cycle time 1 ms 	Yes		
+24V	X2-2 X2-14	<ul style="list-style-type: none"> Auxiliary voltage UV = 24 V DC + 25 %, short-circuit-proof $I_{max} = 100$ mA (overall, also includes driver currents for outputs OSD00 and OSD01, OSD02 and OSD03) External 24 V supply to control electronics in case of power failure possible, current consumption $I_{max} = 1000$ mA + holding brake current Supply tolerance + 20 % ATTENTION: Depending on the power supply unit type, an isolating diode may be required to protect it, as feedback may occur depending on the tolerances of the 24 V of the CDE/CDB and the 24 V power supply unit. 	Yes		
Digital ground					
DGND	X2-1 X2-13	<ul style="list-style-type: none"> Reference ground for 24 V 			

1) Applicable to limited degree

Table 3.7 Specification of control connections - CDE3000

Brake driver X9

Connector X9 is intended for connection of a motor brake.

Brake driver X9		Electrical isolation	Brake driver X9
OSD03 DGND	X9-1 X9-2	ja	
Short-circuit proof Cable break monitoring <ul style="list-style-type: none"> 24 V external voltage supply required ($I_{IN} = 2.1 \text{ A}$) Suitable for actuation of a motor holding brake $I_{max} = 2.0 \text{ A}$ to $\vartheta_{Umax} < 45 \text{ °C}$ Reduced from I_{max} (with external 24 V supply) Overcurrent causes shutdown Also usable as configurable digital output without external voltage supply. Without external voltage supply $I_{MAX} = 50 \text{ mA}$ 			

Table 3.8 Specification of terminal connections X9

Standard terminal assignment CDE

Terminal assignment in **factory setting**

Preset solution speed control, +10 V reference, control via terminal.

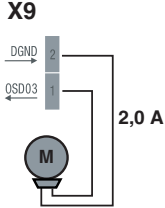
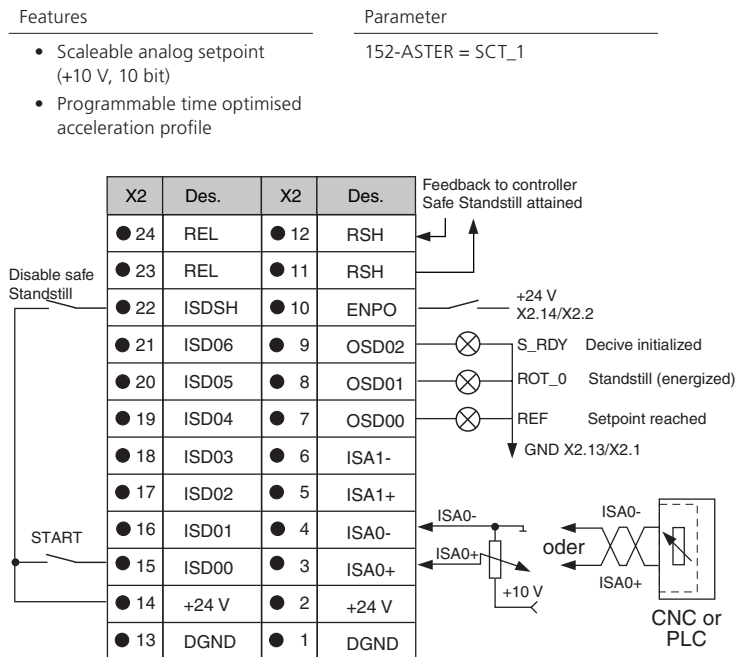

Figure 3.15 Control terminals, traction drive without encoder evaluation

3.7.2 CDE encoder connection of LTi motors

To connect the LTi synchronous motors please use the ready made-up motor cable (for type see figure 3.16) and encoder cables (for type see figure 3.16).

Matching motor - encoder cable - drive controller connection

Compare the rating plates of the components. Make absolutely sure to use the correct components according to variant A, B or C!

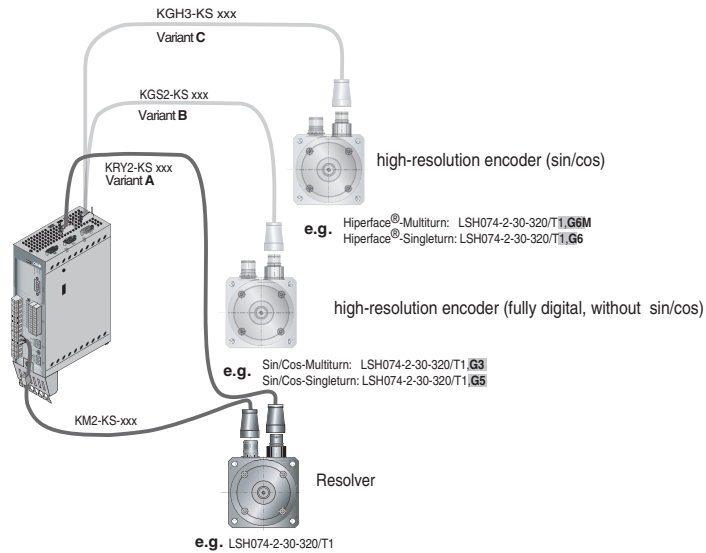

Figure 3.16 Matching motor/encoder cable



NOTE: The encoder cable must not be split, for example to route the signals via terminals in the switch cabinet. Ensure that the knurled screws on the D-sub connector plug are secured!

What encoder types are available for the LTi motors and what type of encoder cable should be used?

Variant	Motor (with built-in encoder)	Encoder cable	Connection of the drive controller
A	With resolver 1R, 3R, 5R e.g. LSH/LST074-2-30-320/T1,1R	KRY2-KSxxx	X6
B	With encoder G3, or G5 (absolute value SSI) r.g. LSH/LST074-2-30-320/T1,G3	KGS2-KSxxx	X7
C	Incremental encoder variants TTL and SinCos	-	X7
D	G6: = Sin/Cos Single turn encoder with HIPERFACE® interface e.g. LSH/LST 074-2-30-320/T1,G6.1S	KGH3-KSxxx	X7
	G6M: = Sin/Cos Multi-turn encoder with HIPERFACE® interface e.g. LSH/LST 074-2-30-320/T1,G6.1M	KGH3-KSxxx	X7

Table 3.9 Motor encoder – encoder cable variants



NOTE: In the event of simultaneous connection of a resolver to X6 and an encoder to X7, the device should be supplied with a voltage of 24V / 1 A (X2).

Ready made-up encoder cable

Conformance to specifications can only be assured when using the LTI system cables.

Order code	K	RY2	-	KS	005
Encoder cable					
Ready made-up cable					
Resolver cable		RY2			
Encoder cable SSI (G3, G5)		GS2			
Encoder cable Sin/Cos Hiperface® (G6.1 and G6.2)		GH3			
Encoder system				KS	
Festoon-compatible					
Version					
Length 2 m					002
Length 3 m					003
Length 5 m					005
Length 8 m					008
Length 10 m					010
Length 15 m					015
Length 20 m					020
Cable length					



Ready made-up encoder cable

Cable type		KRY2-KSxxx	KG52-KSxxx	KGH3-KSxxx
For drive controller		CDE3000		
For encoder system		Resolver	G3, G5, G12.x (Single- / Multi-turn encoder with SSI-/EnDat- interface)	G6, G6.x (Single- / Multi-turn encoder with HIPERFACE®- interface)
Festoon-compatible				
Minimum bending radius:	in fixed installation	-	40 mm	-
	in flexible use	90 mm	100 mm	90 mm
Temperature range:	in fixed installation	-40 ... +85 °C	-35 ... +80 °C	-40 ... +85 °C
	in flexible use		-40 ... +85 °C	
Cable diameter approx.		8.8 mm		
Material of outer sheath		PUR		
Resistance		Resistant to oil, hydrolysis and microbic attack (VDE0472)		
Approvals		UL-Style 20233, 80°C - 300 V, CSA-C22.2N.210 -M90, 75°C - 300 V FT1		
Assignment of wires		1 = S2 2 = S4 3 = S1 4 = n.c. 5 = PTC+ 6 = R1 7 = R2 8 = n S3 9 = PTC-	1 = A- 2 = A+ 3 = Vcc (+5 V) 4 = DATA+ 5 = DATA- 6 = B- 8 = GND 11 = B+ 12 = Vcc (Sense) 13 = GND (Sense) 14 = CLK+ 15 = CLK- 7, 9, 10 = n.c.	1 = REFCOS 2 = +COS 3 = Us 7 - 12 V 4 = Data+ RS485 5 = Data- RS485 6 = REFSIN 7 = Jumper to PIN 12 8 = GND 11 = +SIN 12 = Jumper to PIN 7 9, 10, 13, 14, 15 = n.c.

Table 3.10 Technical data

3.7.3 Third-party motor encoder connection to CDE3000

Resolver

A resolver is connected to slot X6 (9-pin D-Sub female).

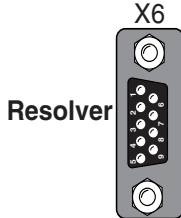
X6/Pin	Function	Figure
1	Sin+ / S2 / (sin +)	
2	Refsin / S4 / (Refsin)	
3	Cos+ / S1 / (cos+)	
4	+ 5 V (opposite Pin 7)	
5*	J + (PTC, KTY, Klixon)	
6	Ref+ / R1 / (Ref+)	
7	Ref- / R2 / (Ref-)	
8	Refcos / S3 / (Refcos)	
9*	J - (PTC, KTY, Klixon)	

* The motor PTC must be adequately insulated against the motor winding (safe isolation 4 kV test voltage). When using LTI motors this insulation is provided.

Table 3.11 Pin assignment X6

High-resolution encoders

The following encoder types can be connected via encoder interface X7.

- Incremental TTL encoder
- Incremental Sin/Cos encoder
- SSI encoder without Sin/Cos (fully digital)
- Sin/Cos Hiperface® encoder



NOTE:

- Encoder voltage supply
 - Voltage supply to encoder: + 5 V +/-5 %, max. current consumption 150 mA (including load)
 - The encoders must have a separate sensor cable connection. The sense cables are required to measure a supply voltage drop on the encoder cable. Only use of the sensor cables ensures that the encoder is supplied with the correct voltage. Always connect the sensor cables!
- Incremental encoder with RS422-compatible track signals (TTL compatible)
 - 32-8192 pulses per revolution
- SSI multi-turn encoder as per reference list with the general specifications:
 - Transfer protocol “SSI”, gray-coded
 - 25 bit multi-turn (12/13 bit multi-/single-turn information, MSB first)

The electrical specification of the interface is given in Table 3.12, the terminal assignment in Table 3.7.4.

Specification of interface X7 for high-resolution encoders

	TTL encoder	SSI encoder	Sin/Cos Hiperface®
Connection	Miniature D-SUB 15-pin socket (high-density)		
Interface	RS422 (differential)		
Surge terminating impedance	Spur A, B, R: 120 W (internal)	DATA: 120 W (internal) CLK: no termination required	DATA: 120 W (internal) CLK: no termination required
Max. signal frequency f_{Limit}	500 kHz		
Voltage supply	+ 5 V \pm 5% (controlled via sensor cables) max. 150 mA not isolated from the control electronics		7 to 12 V (typ. 11 V + 5% / 100 mA)
Sampling rate of the controls	4 kHz	4 kHz	4 kHz
Interface log	-	SSI (Graycode)	Hiperface®
Lines per revolution / resolution	32-8192	13 bit (single-turn) 12 bit (multi-turn)	15 bit (single-turn) 12 bit (multi-turn)
Max. cable length	50 m (further cable specifications as specified by motor manufacturer)		

Table 3.12 Specification of encoder interface X7 CDE3000

Select the cable type specified by the motor or encoder manufacturer, bearing in mind the following:

- Use only shielded cables. Apply the shield on both sides.
- Connect the differential track signals A, B, R or CLK, DATA to each other via twisted-pair cables.
- Do not separate the encoder cable, for example to route the signals via terminals in the switch cabinet.

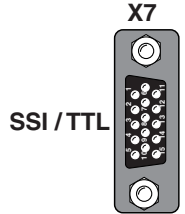
X7/Pin	TTL function	SSI function	Absolute encoder HIPERFACE®	Figure
1	A-, (Track A) ¹⁾	don't use	REFCOS	
2	A+, (Track A)	don't use	+COS	
3	+ 5 V (150 mA)		7 bis 12 V / (typ. 11 V) 100 mA ³⁾	
4	don't use	Data + differential input RS485	R+ / Data +	
5	don't use	Data - differential input RS485	R- / Data -	
6	B-, (Track B) ¹⁾	don't use	REFSIN	
7	don't use	don't use	U _S - Switch ⁴⁾	
8	GND (the 5 V at Pin 3)		GND	
9	R- (zero pulse) ¹⁾	don't use	∅- (PTC, KTY, Klixon) connected internal with X6/9. ²⁾	
10	R+ (zero pulse)	don't use	∅+ (PTC, KTY, Klixon) connected internal with X6/5. ²⁾	
11	B+, (Track B) ¹⁾	don't use	+SIN	
12	Sensor + Sensor cable to measure the 5 V supply to the encoder		U _S - Switch ⁴⁾	
13	Sensor - Sensor cable to measure the 5 V supply to the encoder		-	
14	don't use	CLK + differential output, clock signal	-	
15	don't use	CLK - differential output, clock signal	-	

¹⁾ The cables of tracks A, B, R and Data are terminated internally with 120 Ω.
²⁾ It is imperative you heed the ATTENTION note in Table 3.13!
³⁾ The sum of the currents drawn at X7/3 and X6/4 must not exceed the value stated!
⁴⁾ After connecting pin 7 and pin 12, there is a voltage of 11.8 V on X7/3 and X6/4!

Table 3.13 Pin assignment of encoder interface X7 CDE3000

3.7.4 Motor temperature monitoring - CDE



ATTENTION! When connected to terminal X3, the motor temperature sensor must provide **basic insulation**. When connected to terminal X6 or X7, it must provide **increased insulation** in accordance with EN 61800-5-1!

Connection	Sensor type	Insulation in motor winding
X3	Temperature switch (Klixon), PTC	Sensor with basic insulation
X6	Temperature switch (Klixon), PTC, KTY	Sensor with reinforced insulation
X7	Temperature switch (Klixon), PTC, KTY	Sensor with reinforced insulation

Table 3.14 Connection assignment, motor temperature sensor

3.7.5 Connection of LTi motors

Please use the ready made-up motor cable KM2-KS-005 to connect the LTi servo motors, series LSH and LST.

Ready made-up motor cable



Order code	KM 2 - KS	005
Motor cable		
Ready made-up cable		
Festoon compatible	KS	
Version		
Length 2 m		002
Length 3 m		003
Length 5 m		005
Length 8 m		008
Length 10 m		010
Length 15 m		015
Length 20 m		020
Cable length		

Technical data – motor cable		KM2-KSxxx
Minimum bending radius:	in fixed installation	60 mm
	in flexible use	120 mm
Temperature range:	in fixed installation	-50 ... +90 °C
	in flexible use	-50 ... +90 °C
Cable diameter approx.		∅ 12 mm
Material of outer sheath		PUR
Wiring		U = 1 V = 2 W = 3 Ground = ge/gn PTC = 5 PTC = 6 Brake + = 7 Brake - = 8
Note: For motors up to 16 A rated current with plug-in power connection		

Table 3.15 Technical data – ready made-up motor cable



NOTE: Wires 5 and 6 (PTC) are only required for motors with optical encoders (G3, G5, G6, G6M). In the LSH motors with resolvers the PTC monitoring is by way of the resolver cable.

3.7.6 Connection of third-party motors

Step	Action	Comment
1.	Define cable cross-section depending on maximum current and ambient temperature.	Cable cross-section to VDE0100, part 523, see section 3.6.
2.	Wire the motor phases U, V, W by way of a shielded cable and ground the motor to X1/ \varnothing or X21.	Mount shield at both ends to reduce interference emission.
3.	Wire the temperature sensor (PTC, KTY, Klixon) (if present) to X3 using separately shielded cables and activate temperature evaluation via DriveManager 3.x.	Mount shield at both ends to reduce interference emission.



ATTENTION: Make sure the temperature monitor used has adequate insulation from the motor winding (basic isolation (2 kV test voltage)).

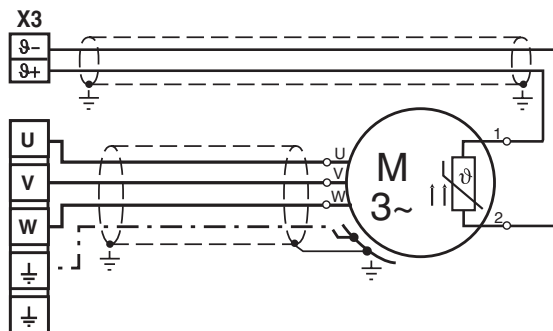

Figure 3.17 Motor connection



NOTE: The CDE3000 positioning controller is protected against short-circuit and ground faults at the terminals when in operation. In the event of a short-circuit or ground fault in the motor cable, the power stage is disabled and an error message is delivered.

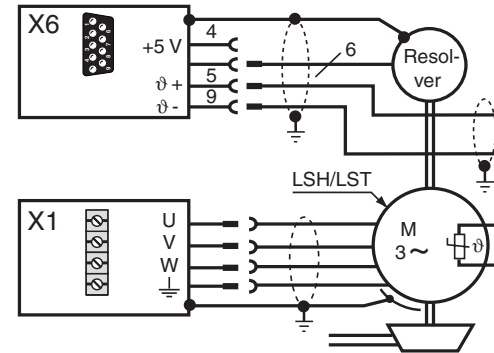

Figure 3.18 Connection of PTC to LSH/LST motors

Shield connection and EMC installation – CDE



NOTE THE FOLLOWING POINTS:

- Execute shield contact via shield connection STxx. For size 7 (45 kW/ 90 A) and above, execute the shield connection directly beneath the device on the backing plate.
- For EMC compatible installation the motor terminal box must be HF-tight (metal or metallized plastic). For cable introduction, packing glands with large-area shield contact should be used.

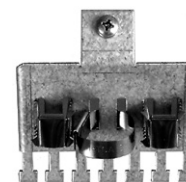

Shield connection plate STxx



Shield connection with clip and metal cable tie

For more information on current capacity, technical data and environmental conditions refer to appendices A1 to A3.

On this screen (Figure 3.19) the matching motor temperature sensor (PTC) and temperature-dependent switches and an I²t monitor can be set to protect the motor.

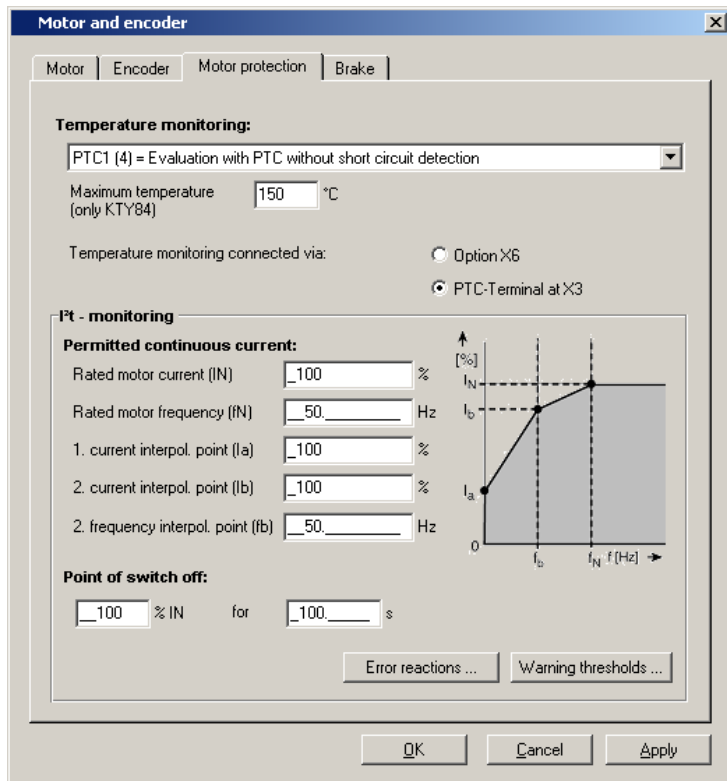

Figure 3.19 Motor protection tab

3.8 CDB3000

3.8.1 Control connections - CDB3000

Step	Action	Comment
1.	Check whether you already have a SmartCard or a DriveManager 3.x data set with a complete device setup, i.e. the drive has already been planned as required.	
2.	If this is the case, a special control terminal assignment applies. Please contact your project engineer to obtain the terminal assignment!	Bulk customers For details of how to load the data set into the positioning controller refer to section 4.2.
3.	Choose a terminal assignment.	Initial commissioning There are various preset solutions available to make it easier to commission the device.
4.	Wire the control terminals with shielded cables. The only essential signals are the ENPO signals and a start signal (with control via terminal).	Earth the cable shields over a wide area at both ends. Cable cross-section maximum 1.5 mm ² or two strands per terminal at 0.5 mm ²
5.	Keep all contacts open (inputs inactive).	
6.	Check all connections again!	Continue with commissioning in chapter 4.



NOTE THE FOLLOWING POINTS:

- Always wire the control terminals with shielded cables.
- Lay the control cables separately from the mains power and motor cables.
- The CDE/CDB3000 Application Manual presents more preset drive solutions.

- A cable type with double copper braiding with 60 - 70 % coverage must be used for all shielded connections

Specification of control connections - CDB3000

Des.	Terminal	Specification	Floating	Control terminal																					
Analog inputs																									
ISA00	X2-2	<ul style="list-style-type: none"> • $U_{IN} = +10\text{ V DC}$, $\pm 10\text{ V DC}$ • $I_{IN} = (0) 4\text{-}20\text{ mA DC}$, software-switchable to: • 24 V digital input, PLC compatible • Switching level Low/High: $< 4.8\text{ V} / > 8\text{ V DC}$ • Resolution 10 bit • $R_{IN} = 110\text{ k}\Omega$ • Terminal scan cycle = 1 ms • Tolerance: U: $\pm 1\%$ of measuring range end value I: $\pm 1\%$ v. M. 	against digital GND	<table border="1"> <tr><td>X2</td></tr> <tr><td>OSD02 normally open</td></tr> <tr><td>OSD02 +24 V Relais</td></tr> <tr><td>OSD02 normally closed</td></tr> <tr><td>DGND</td></tr> <tr><td>OSD01</td></tr> <tr><td>OSD00</td></tr> <tr><td>DGND</td></tr> <tr><td>+24 V</td></tr> <tr><td>ISD03</td></tr> <tr><td>ISD02</td></tr> <tr><td>ISD01</td></tr> <tr><td>ISD00</td></tr> <tr><td>ENPO</td></tr> <tr><td>+24 V</td></tr> <tr><td>+24 V</td></tr> <tr><td>OSAO</td></tr> <tr><td>AGND</td></tr> <tr><td>ISA01</td></tr> <tr><td>ISA00</td></tr> <tr><td>+10,5 V</td></tr> </table>	X2	OSD02 normally open	OSD02 +24 V Relais	OSD02 normally closed	DGND	OSD01	OSD00	DGND	+24 V	ISD03	ISD02	ISD01	ISD00	ENPO	+24 V	+24 V	OSAO	AGND	ISA01	ISA00	+10,5 V
X2																									
OSD02 normally open																									
OSD02 +24 V Relais																									
OSD02 normally closed																									
DGND																									
OSD01																									
OSD00																									
DGND																									
+24 V																									
ISD03																									
ISD02																									
ISD01																									
ISD00																									
ENPO																									
+24 V																									
+24 V																									
OSAO																									
AGND																									
ISA01																									
ISA00																									
+10,5 V																									
ISA01	X2-3	<ul style="list-style-type: none"> • $U_{IN} = +10\text{ V DC}$, software-switchable to: • 24 V digital input, PLC compatible • Switching level Low/High: $< 4.8\text{ V} / > 8\text{ V DC}$ • Resolution 10 bit • $R_{IN} = 110\text{ k}\Omega$ • Terminal scan cycle = 1ms • Tolerance: U: $\pm 1\%$ of measuring range end value 	against digital GND																						
Analog output																									
OSA00	X2-5	<ul style="list-style-type: none"> • PWM with carrier frequency 1 kHz • Resolution 10 bit • $R_{OUT} = 100\ \Omega$ • $U_{out} = +10\text{ V DC}$ • $I_{max} = 5\text{ mA}$ • Short-circuit proof • Tolerance $\pm 2.5\%$ 																							
Digital inputs * With variant CDB3000,SH: see section 3.13: Safe Torque Off (STO)																									

Table 3.16 Specification of control connections - CDB3000

Des.	Terminal	Specification	Floating	Control terminal																					
ISD00 *	X2-9	<ul style="list-style-type: none"> • Limit frequency 5 kHz • PLC compatible • Switching level Low/High: $< 5\text{ V} / > 18\text{ V DC}$ • I_{max} at 24 V = 10 mA • $R_{IN} = 3\text{ k}\Omega$ • internal signal delay time $\approx 100\ \mu\text{s}$ • Terminal scan cycle = 1ms 	Yes	<table border="1"> <tr><td>X2</td></tr> <tr><td>OSD02 normally open</td></tr> <tr><td>OSD02 +24 V Relais</td></tr> <tr><td>OSD02 normally closed</td></tr> <tr><td>DGND</td></tr> <tr><td>OSD01</td></tr> <tr><td>OSD00</td></tr> <tr><td>DGND</td></tr> <tr><td>+24 V</td></tr> <tr><td>ISD03</td></tr> <tr><td>ISD02</td></tr> <tr><td>ISD01</td></tr> <tr><td>ISD00</td></tr> <tr><td>ENPO</td></tr> <tr><td>+24 V</td></tr> <tr><td>+24 V</td></tr> <tr><td>OSAO</td></tr> <tr><td>AGND</td></tr> <tr><td>ISA01</td></tr> <tr><td>ISA00</td></tr> <tr><td>+10,5 V</td></tr> </table>	X2	OSD02 normally open	OSD02 +24 V Relais	OSD02 normally closed	DGND	OSD01	OSD00	DGND	+24 V	ISD03	ISD02	ISD01	ISD00	ENPO	+24 V	+24 V	OSAO	AGND	ISA01	ISA00	+10,5 V
X2																									
OSD02 normally open																									
OSD02 +24 V Relais																									
OSD02 normally closed																									
DGND																									
OSD01																									
OSD00																									
DGND																									
+24 V																									
ISD03																									
ISD02																									
ISD01																									
ISD00																									
ENPO																									
+24 V																									
+24 V																									
OSAO																									
AGND																									
ISA01																									
ISA00																									
+10,5 V																									
ISD01	X2-10	<ul style="list-style-type: none"> • Limit frequency 500 kHz • PLC compatible • Switching level Low/High: $< 5\text{ V} / > 18\text{ V DC}$ • I_{max} at 24 V = 10 mA • $R_{IN} = 3\text{ k}\Omega$ • internal signal delay time $\approx 2\ \mu\text{s}$ • Terminal scan cycle = 1ms • R input (zero pulse) 24 V - HTL encoder against DGND 	Yes																						
ISD02	X2-11	<ul style="list-style-type: none"> • Limit frequency 500 kHz • PLC compatible • Switching level Low/High: $< 5\text{ V} / > 18\text{ V DC}$ • I_{max} at 24 V = 10 mA • $R_{IN} = 3\text{ k}\Omega$ • internal signal delay time $\approx 2\ \mu\text{s}$ • Terminal scan cycle = 1ms • A input with square encoder evaluation for 24 V HTL encoder against DGND Permissible pulse count 32...8192 pulses per rev. see section 	Yes																						
ISD03	X2-12	<ul style="list-style-type: none"> • Limit frequency 500 kHz • PLC compatible • Switching level Low/High: $< 5\text{ V} / > 18\text{ V DC}$ • I_{max} at 24 V = 10 mA • $R_{IN} = 3\text{ k}\Omega$ • internal signal delay time $\approx 2\ \mu\text{s}$ • Terminal scan cycle = 1 ms • B input with square encoder evaluation for 24 V HTL encoder against DGND Permissible pulse count 32...8192 pulses per rev. 																							

Table 3.16 Specification of control connections - CDB3000

Des.	Terminal	Specification	Floating	Control terminal
ENPO	X2-8	<ul style="list-style-type: none"> Power stage enable = High level Switching level Low/High: < 5 V / > 18 V DC I_{max} at 24 V = 10 mA $R_{IN} = 3 \text{ k}\Omega$ internal signal delay time = 20 μs, with variant CDB-SH = 10 ms Terminal scanning cycle = 1 ms PLC compatible 	Yes	X2 OSD02 normally open 20 OSD02 +24 V Relais 19 OSD02 normally closed 18 DGND 17 OSD01 16 OSD00 15 DGND 14 +24 V 13 ISD03 12 ISD02 11 ISD01 10 ISD00 9 ENPO 8 +24 V 7 +24 V 6 OSA0 5 AGND 4 ISA01 3 ISA00 2 +10,5 V 1
Digitale outputs				
OSD00	X2-15	<ul style="list-style-type: none"> Short-circuit proof PLC compatible $I_{max} = 50 \text{ mA}$ internal signal delay time = 250 μs Terminal scanning cycle = 1ms Protection against inductive load High-side driver 	Yes	
OSD01	X2-16	<ul style="list-style-type: none"> Short-circuit proof PLC compatible $I_{max} 50 \text{ mA}$ internal signal delay time = 2 μs Terminal scanning cycle = 1 ms No internal freewheeling diode; provide external protection High-side driver 		
1) applicable to limited degree				
Relay output With variant CDB3000,SH: see section 3.13: Safe Torque Off (STO))				
OSD02	X2-18 X2-19 X2-20	<ul style="list-style-type: none"> Relay, 1 changeover contact 25 V / 1 A AC, usage categorie AC1, cos j: =1 30 V / 1 A DC, usage categorie DC1, cos j: =1 Operating delay approx. 10 ms 0.2 A with polyswitch for CDB-SH 	Yes	
Voltage supply				
+10.5V	X2-1	<ul style="list-style-type: none"> Auxiliary voltage UR =10.5 V DC Short-circuit proof $I_{max_in} = 10 \text{ mA}$ 	-	

Table 3.16 Specification of control connections - CDB3000

Des.	Terminal	Specification	Floating	Control terminal
+24V	X2-6 X2-7 X2-13	<ul style="list-style-type: none"> Auxiliary voltage $U_V = 24 \text{ V DC} + 25 \%$, Short-circuit proof $I_{max} = 100 \text{ mA}$ (overall, also includes driver currents for outputs OSD00 and OSD01) If no encoder is connected to X7, $I_{max} = 200 \text{ mA}$ applies (overall, also includes driver currents for outputs OSD00 and OSD01) External 24 V supply to control electronics in case of power failure possible, current consumption $I_{max} = 900 \text{ mA}$ Supply voltage tolerance + 20 % ATTENTION: Depending on the power supply unit type, an isolating diode may be required to protect it, as feedback may occur depending on the tolerances of the 24 V of the CDB and the 24 V power supply unit. 	Yes	X2 OSD02 normally open 20 OSD02 +24 V Relais 19 OSD02 normally closed 18 DGND 17 OSD01 16 OSD00 15 DGND 14 +24 V 13 ISD03 12 ISD02 11 ISD01 10 ISD00 9 ENPO 8 +24 V 7 +24 V 6 OSA0 5 AGND 4 ISA01 3 ISA00 2 +10,5 V 1
AGND	X2-4	<ul style="list-style-type: none"> Isolated from DGND 		
Digital ground				
DGND	X2-14 X2-17	<ul style="list-style-type: none"> Isolated from AGND 		
STO Only with special variant CDB3x.xxx,SH !				
ISD00	X2-9	<ul style="list-style-type: none"> Limit frequency 5 kHz PLC compatible Switching level Low/High: <5 V / >18 V DC I_{max} at 24 V = 10 mA $R_{IN} = 3 \text{ k}\Omega$ internal signal delay time = 100 μs Terminal scanning cycle = 1ms 	Yes	

Table 3.16 Specification of control connections - CDB3000

Des.	Terminal	Specification	Floating	Control terminal	
OSD02	X2-18 X2-19 X2-20	<ul style="list-style-type: none"> Relay, 1 changeover contact 25 V / 200 mA AC, usage categorie AC1 30 V / 200 mA DC, usage categorie DC1 Operating delay approx 10 ms Protection against overload by device-internal resettable cut-out (PTC) 3 x 10⁶ switching cycles 	Yes	X2	
				OSD02 normally open	20
				OSD02 +24 V Relats	19
				OSD02 normally closed	18
				DGND	17
				OSD01	16
				OSD00	15
				DGND	14
				+24 V	13
				ISD03	12
				ISD02	11
				ISD01	10
				ISD00	9
				ENPO	8
				+24 V	7
				+24 V	6
				OSA0	5
				AGND	4
				ISA01	3
				ISA00	2
+10,5 V	1				

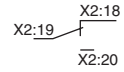
Table 3.16 Specification of control connections - CDB3000



NOTE: In the range > 5 V / < 18 V the response of the inputs is undefined.

Standard terminal assignment - CDB3000 (factory setting)

Preset solution speed control, +10 V reference, control via terminal.

Features

- Scaleable analog reference (+10 V, 10 bit)
- Programmable time optimised acceleration profile

Parameter

152-ASTER = SCT_1

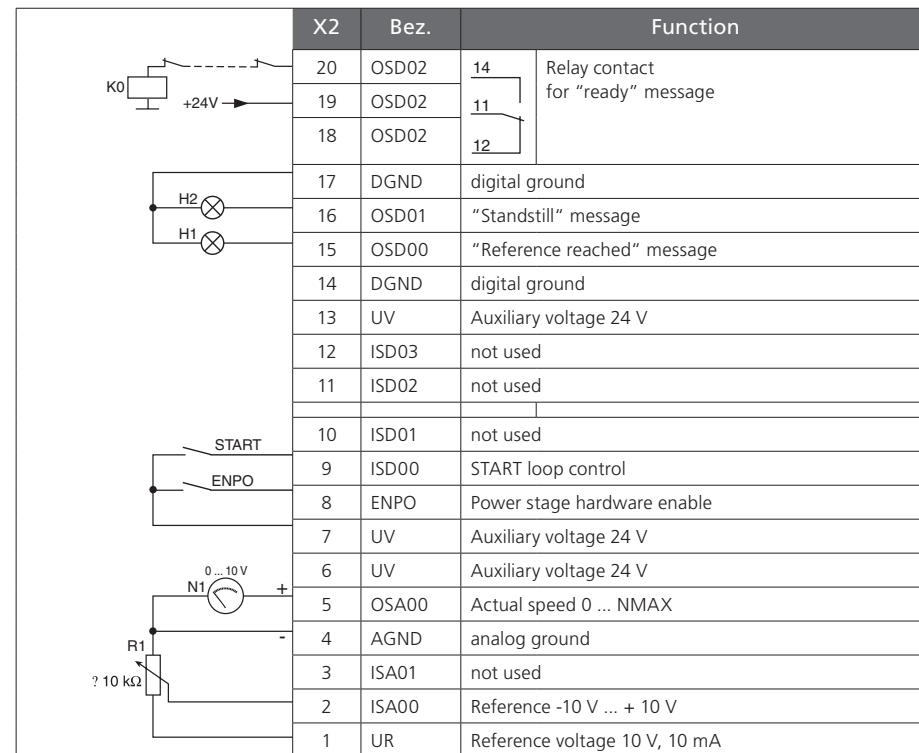

Figure 3.20 Control terminals, traction drive without encoder evaluation





NOTE THE FOLLOWING POINTS:

- For terminal assignments for further preset solutions refer to CDE/CDB3000 Application Manual.

- You can set the control terminal individually to suit your application.

3.8.2 Encoder connection - CDB3000

Step	Action
 1.	Select the appropriate encoder type.
 2.	Wire the encoder connection with shielded cables.

High-resolution encoders

By encoder interface X7 an encoder can be connected to an

- incremental TTL interface or
- SSI interface

Only encoders with the following specification may be connected:



NOTE:

- Encoder voltage supply
 - Voltage supply to encoder: + 5 V ±5 %, max. current consumption 150 mA (including load)
 - The encoders must have a separate sensor cable connection. The sense cables are required to measure a supply voltage drop on the encoder cable. Only use of the sensor cables ensures that the encoder is supplied with the correct voltage.
Always connect the sensor cables!
- Incremental encoder with RS422-compatible track signals (TTL compatible)
 - 32-8192 pulses per revolution
- SSI multi-turn encoder as per reference list with the general specifications:
 - Transfer protocol "SSI", gray-coded
 - 25 bit multi-turn (12/13 bit multi-/single-turn information, MSB first)

The electrical specification of the interface is given in Table 3.15, the terminal assignment in Table 3.9.

Specification of interface for high-resolution encoders

Step	Action	Comment
Connection	Miniature D-SUB 15-pin socket (high-density)	
Interface	RS422 (differential)	
Surge terminating impedance	Track A, R: 120 Ω (internal) Track B wired by customer	DATA: 120 Ω (internal) CLK: no termination required
Max. signal frequency f_{Limit}	500 kHz	
Voltage supply	+ 5 V ±5 % (controlled via sensor lines) max. 150 mA not isolated from the control electronics	
Sampling rate of the controls	4 kHz	4 kHz
Interface log	-	SSI (Graycode)
Lines per revolution / resolution	32-8192	13 bit (Single-turn) 25 bit (Multi-turn)
Max. cable length	50 m (further cable specifications as specified by motor manufacturer)	

Table 3.17 Specification of encoder interface X7

Select the cable type specified by the motor or encoder manufacturer, bearing in mind the following:

- Use only shielded cables. Apply the shield on both sides.
- Connect the differential track signals A, B, R or CLK, DATA to each other via twisted-pair cables.
- Do not separate the encoder cable, for example to route the signals via terminals in the switch cabinet.

X7/Pin	TTL function	SSI function	D-Sub
1	A-	DATA-	
2	A+	DATA+	
3	+5 V (150 mA)	+5 V (150 mA)	
4	don't use	don't use	
5	don't use	don't use	
6	B-	CLK-	
7	don't use	don't use	
8	GND	GND	
9	R-	don't use	
10	R+	don't use	
11	B+	CLK+	
12	+5 V (Sensor)	+5 V (Sensor)	
13	GND (Sensor)	GND (Sensor)	
14	B- (connect to pin 15 to activate terminating resistor) ¹⁾	don't use	
15	Jumper 120 Ω termination track B (connect to pin 14 to activate terminating resistor) ¹⁾	don't use	

1) Track B must be terminated via a jumper between pin 14 and 15. The terminating resistor (120 Ω) is built into the device. The customer must execute the wiring, as track CLK (pin 6, 11) must not be terminated if an SSI interface is used.

Table 3.18 Assignment of encoder interface X7 - CDB3000

Connection of 2nd encoder via X2

While the TTL/SSI encoder is being connected to X7 (see section 3.8.2), an HTL encoder can be evaluated via the control terminal.

When using simultaneously, as described in Figure 3.21 the Use TTL/SSI encoder at X7 only for position control. The HTL encoder to X2 is then responsible for motor commutation and subsidiary speed control.

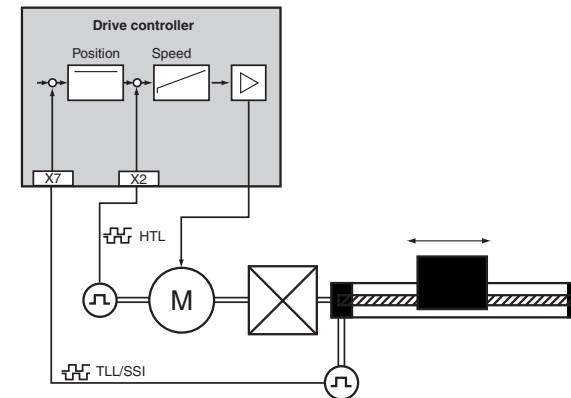

Figure 3.21 Drive with two measurement systems

	Specification	Comment
Interface	HTL (24 V)	Low = < 5 V, High = > 18 V
Max. signal frequency f_{Limit}	150 kHz	
Voltage supply	+ 24 V, max. 80 mA	The total current capacity of the control terminal is limited to 100 mA. Where the encoder's current consumption is higher, its supply must be provided by the customer in line with the specification below.
Sampling rate of the controls	4 kHz	
Lines per revolution	32-8192	
Max. cable length	30 m	Select the cable type specified by the motor or encoder manufacturer. Use only shielded cables. Apply the shield on both sides. Do not separate the encoder cable, for example to route the signals via terminals in the switch cabinet.

Table 3.19 Electrical specification of the HTL encoder interface

HTL encoder terminal assignment

X2	Terminal designation	HTL function
14	GND	GND
13	+24 V (100 mA for complete control terminal)	+24 V
12	ISD03	B+
11	ISD02	A+

Table 3.20 Assignment for HTL encoder connection to X2



NOTE: Inverted encoder signals or a zero pulse cannot be connected or evaluated.

HTL encoder supply

If connecting an HTL encoder causes the maximum current of 100 mA from the 24 V auxiliary voltage to be exceeded, feed the encoder with external voltage as shown in Figure 3.22.

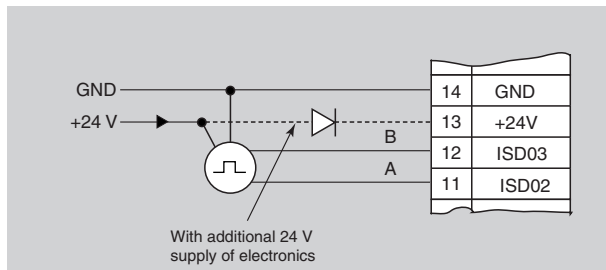

Figure 3.22 Supplying the HTL encoder with external voltage feed

If external voltage is still required to feed the drive controller (e.g. to run field bus communication with the mains voltage off), isolate it from the controller voltage with a diode.

For further project planning notes relating to encoder selection, refer to section 3.8.2.

3.8.3 Motor connection on the CDB3000

Step	Action	Comment
1.	Define cable cross-section depending on maximum current and ambient temperature.	Cable cross-section to VDE0100, part 523, see section 3.6.
2.	Wire the motor phases U, V, W by way of a shielded cable and ground the motor to X1/.	Mount shield at both ends to reduce interference emission.
3.	Wire the temperature sensor PTC (if fitted) with separately shielded cables.	Mount shield at both ends to reduce interference emission.



ATTENTION: Make sure the temperature monitor used has adequate insulation from the motor winding (basic isolation, test voltage 2 kV).

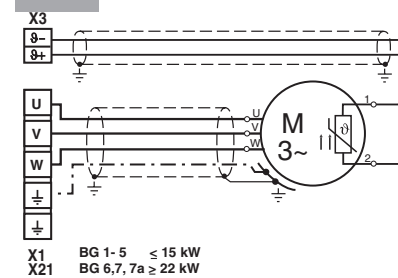

Figure 3.23 Connection of the motor on the CDB3000



NOTE: The CDB3000 positioning controller is protected against short-circuit and ground faults at the terminals when in operation. In the event of a short-circuit or ground fault in the motor cable, the power stage is disabled and an error message is delivered.

3.8.4 Motor temperature monitoring – CDE



ATTENTION! When connected to terminal X3, the motor temperature sensor must provide basic insulation.

Connection	Sensor type	Insulation in motor winding
X3 (CDE/CDB)	Temperature switch (Klixon), PTC, KTY	Sensor basic insulation

Table 3.21 Motor temperature sensor connection

Shield connection and EMC installation



NOTE THE FOLLOWING POINTS:

- Execute shield contact via shield connection STxx. For size 7 (45 kW/ 90 A) and above, execute the shield connection directly beneath the device on the backing plate.
- For EMC compatible installation the motor terminal box must be HF-tight (metal or metallized plastic). For cable introduction, packing glands with large-area shield contact should be used.

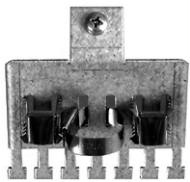

Shield connection sheet STxx



Shield connection with clip and metal cable binder

- For more information on current capacity, technical data and environmental conditions refer to appendices A1 to A3.

Switching in the motor cable



MOTOR SHUTDOWN:

The motor cable must always be switched with the power cut, otherwise problems such as burnt-out contactor contacts, overvoltage or overcurrent shut-off of the controller may occur.

In order to ensure unpowered switching, you must make sure that the contacts of the motor contactor are closed before the controller power stage is enabled. In the reverse case, it is necessary for the contacts to remain closed until the controller power stage is shut down and the motor current is 0.

This is done by configuring appropriate safety times for switching of the motor contactor in the control sequence of your machine or using the special ENMO software function of the CDE/CDB3000 positioning controller.



MULTI-MOTOR OPERATION:

The CDE3000 positioning controllers can be run with several motors configured in parallel. Depending on the application, various project planning conditions must be met, see appendix A4. Multi-motor operation for CDB3000 is not permitted.



ISOLATED SWITCHING IN THE MOTOR CABLE:

The motor cable should always be switched with the power cut, otherwise a fault shutdown may occur.

Function

Start control: Auxiliary contactor K1 is activated on control start. The output frequency (output voltage) of the controller is delayed by the time set in parameter 247-TENMO. This ensures that the motor contactor is closed before the output frequency (output voltage) of the controller runs up.

Stop control: When "Start control" is cancelled the auxiliary contactor K1 drops out after a delay set in parameter 247-TENMO. This ensures that the motor contactor only opens when the power is cut to the power stage of the controller.

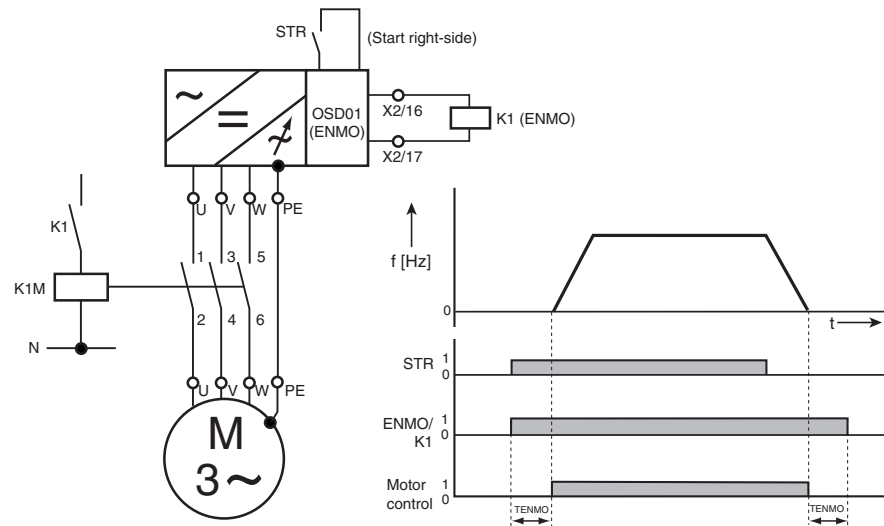

Figure 3.24 Connection example for ENMO. The shield connection is not shown.

3.9 Serial interface (SIO) - CDE/CDB3000

The serial interface (SIO, X4) is used for connection of the DriveManager 3.x and as the slot for the KeyPad. To connect the positioning controller to the PC / DriveManager 3.x the ready made-up RS232 cable CCD-SUB 90X (maximum length 3 m) is used.

Pin assignment X4

Pin no.	Function
1	+15 V DC for keypad KP300 (previously KP200-XL)
2	TxD, send data
3	RxD, receive data
4	don't use
5	GND for +15 V DC of keypad KP300 (previously KP200-XL)
6	+24 V DC (only for KP200)
7	don't use
8	don't use
9	GND for +24 V DC (only for KP200)

Table 3.22 Pin assignment of serial interface X4, CDE/CDB3000

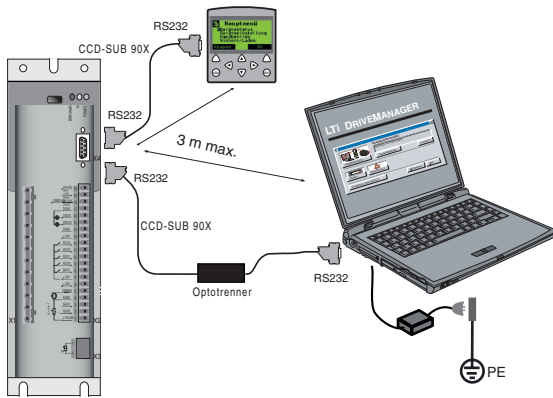

Figure 3.25 Connection X4



ATTENTION: The RS232 port is used solely as a service diagnosis interface. Control via the interface is not permitted. The interface is wired to the potential of the analog inputs. Uncontrolled transient currents passing through the CCD-SUB 90X cable may result in destruction inside the controller and in the PC. We therefore urgently recommend using an opto-isolator.

3.10 CAN interface - CDE/CDB3000

The CANopen interface is built into the drive controller. The connection is made via connector X5. The power supply to the isolated connection is provided by the customer.

Connection	Miniature D-Sub 9-pin plug
Surge terminating impedance - Bus terminator -	A jumper (pin 1-2) activates the internal terminating resistor (120 Ω)
Max. input frequency	1 MHz
Ext. voltage supply	+ 24 V +25%, 50 mA (isolated from drive controller)

Assignment of connection X5:

X5/Pin	Function	D-Sub
1	Jumper on pin 2 for active bus termination	
2	CAN_LOW	
3	CAN_GND	
4	don't use	
5	don't use	
6	CAN_GND	
7	CAN_HIGH	
8	don't use	
9	CAN_+24 V external volateg supply	

Table 3.23 Pin assignment X5

Bus address

The bus address of a CAN node is set by way of a coding switch.

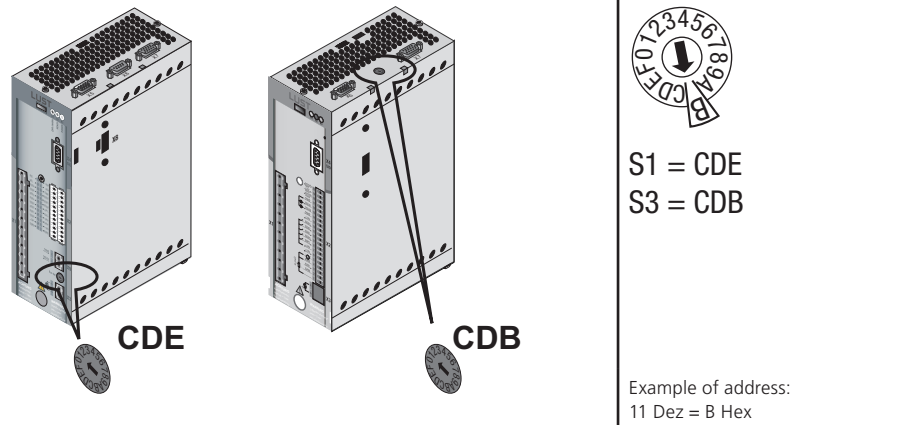

Figure 3.26 Position and setting of coding switches for CAN bus address

A bus address can be alternatively set via parameters. The addresses from the coding switch and the parameter setting are added together.



PROJECT PLANNING AND FUNCTION DESCRIPTION

For notes on this refer to the CANopen communications manual. The interface is switched off with factory default setting ASTER: OLT_1 disabled

3.11 DC network - CDE/CDB3000

The positioning controllers running in regenerative (braking) mode in the DC network feed power into the DC network which is consumed by the motorized drive controllers.



ATTENTION: It is essential that DC network operation be verified at the project planning stage. Please consult your project engineer.

3.12 Braking resistor (RB) - CDE/CDB3000

In regenerative operation, e.g. when braking the drive, the motor feeds energy back to the drive controller. This increases the voltage in the DC link. If the voltage exceeds a threshold value, the internal braking transistor is activated and the regenerated power is converted into heat by way of a braking resistor.

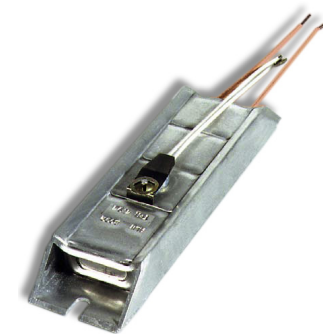
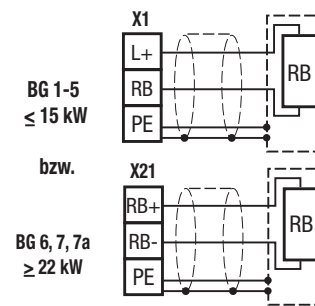

Figure 3.27 Connection brake resistor



ATTENTION: Danger to life! Never wire or disconnect electrical connections while these are live. Always disconnect the power before working on the device. Wait until the DC-link voltage at terminals X1/L+, L- (BG 1-5) or X21/ZK+, ZK- (BG 6-7) has fallen to the safety-low voltage before working on the device (approx. 10 minutes).



ATTENTION: If the error message E-OTI (device heat sink overheating) appears, the connected device must be isolated from the mains, as the cause may be overloading of the braking resistor due to mains overvoltage. Please integrate one of the digital outputs into your control concept accordingly, e.g. set OSDxx to WOTI (= device heat sink temperature warning).

Connection of an external braking resistor



ATTENTION:

- Be sure to follow the installation instructions for the external braking resistor.
- The temperature sensor (bimetal switch) on the braking resistor must be wired in such a way that the connected positioning inverter is disconnected from the mains supply if the system overheats.
- The minimum permissible connection resistance of the positioning inverter must not be infringed – for technical data see appendix 2.
- The braking resistor is built-in to device variant CDE/CDB3X.xxx, Wx.x, BR. No additional braking resistor may be connected to terminals X1/L+ or RB+/RB-; this would damage the inverter module.
- For further information please consult your project engineer.

Monitoring of the internal braking resistor

Variant BR

In positioning controller variant BR - CDB3X.xxx, X, BR braking resistor is built-in to the device. Since overloading of the internal braking resistor may occur, due to mains overvoltage for example, the braking resistor must be specially monitored.

The maximum permissible peak braking power is stipulated in appendix A2. For further information please consult your project engineer.



ATTENTION: An external braking resistor must be monitored by the control system.
The temperature of the braking resistor is monitored by a temperature watchdog (Klixon).
In the event of overheating the positioning controller must be disconnected from the mains supply.

3.13 Safe Torque Off (STO)

Applicable to all devices CDE3000 as well as to all special variants CDB3000 SH up from hardware index 2.4.



NOTE: You will find all information relating to the “STO” function in the document titled “CDE/CDB SH/CDF – Description of the STO safety function” (ID no.: 1001.01B.X-XX).

4 Commissioning



ATTENTION: Commissioning must only be carried out by qualified electricians who have undergone instruction in the necessary accident prevention measures.

4.1 Choice of commissioning

Mode of commissioning	Commissioning steps	Continued on
<ul style="list-style-type: none"> Project planning and commissioning are already complete. Loading of an existing data set. 	Serial commissioning	page 49
<ul style="list-style-type: none"> Initial project planning and commissioning of the drive system 	initial commissioning	page 50
<ul style="list-style-type: none"> Project planning and basic setting of the drive system have been carried out. 	Test run	page 56

4.2 Serial commissioning















Apply this mode of commissioning if you want to put several identical drives into operation (serial commissioning). The same positioning controller type and the same motor must be used for each drive in an identical application.

If you already have a complete data set, skip the subsection headed "Save data set from device to file" (with DriveManager 3.x).

4.2.1 Serial commissioning with DriveManager 3.x

Preconditions:

- All positioning controllers are fully connected.
- The first drive is already fully commissioned into operation.
- A PC running the DriveManager 3.x user software is connected..

Step	Action	Comments
	Connect your PC to the positioning controller of the first drive and switch on the power to the positioning controller.	Use a standard serial cable (9-pin D-SUB female/male).
	Start DriveManager 3.x.	Automatically connects to the linked positioning controller.
	If the connection fails, check the settings on the Tools > Options menu and try again by clicking the  icon.	
	Save the current data set with  , either in the parameter database (directory: <code>c:\.userdata</code>) of the DriveManager 3.x or to a floppy disk (a:).	With icon the current data set of the connected device is always saved. Give the file a name of your choice..
	Disconnect from all devices with 	Connect your PC to the positioning controller of the next drive and switch on the power to the positioning controller.
	With icon establish a link between the DriveManager 3.x and the newly connected device. 	
	With icon load the data set saved in step 4 into the device 	
	With icon select the main window..  Save the setting with 	Repeat steps 4 ... 7 on each of the other drives.



NOTE: For more information on the DriveManager 3.x refer to the DriveManager 3.x manual.

4.3 Initial commissioning

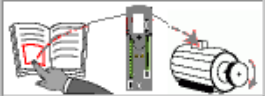

Preconditions	
<ul style="list-style-type: none"> The position controller is fully connected; see section 3 Installed DriveManager 3.x version V3.4 or higher Motor database for motors is installed on PC Device is connected to PC via RS232 interface (X4) 	 <p>Initial commissioning...</p>



ATTENTION: Never wire or disconnect electrical connections while they are live!

Before working on the device disconnect the power. Wait for the DC link capacitors to discharge. Work may only be carried out on the device when the residual voltage (between terminals L+ and L-) is below 60 V!

Connect input ENPO = low level (CDB terminal 8 (X2) / CDE terminal (X2)) to prevent unintentional startup of the motor (power stage disabled, position controller power on).

Preparations		
<ul style="list-style-type: none"> Power up the positioning controller A self-test is carried out Start the DriveManager 3.x Set up the connection to the device. 		DriveManager 3.x > Connect or: Communication > Connect...
<ul style="list-style-type: none"> Open the main "Setup" window 		DriveManager 3.x or : Active device > Change settings

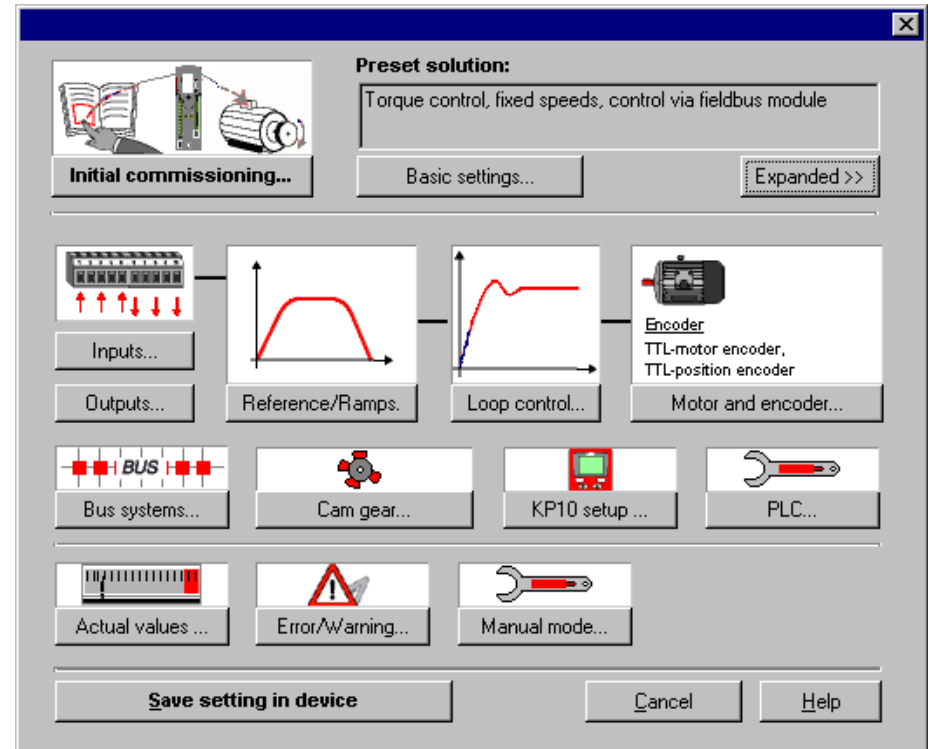
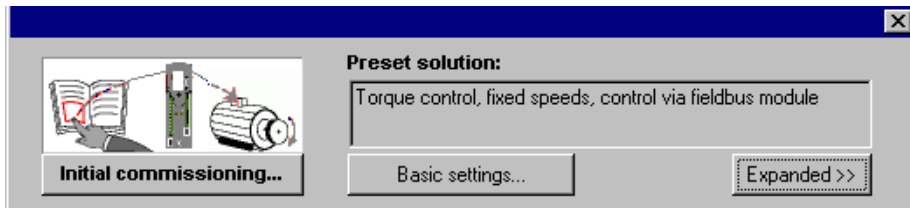

Figure 4.1 Main window for the various settings in the DriveManager 3.x

Continue with:



Loading a preset solution into the RAM automatically configures the position controller. The parameters are set for the following:

- the control location of the drive controller,
- the setpoint source,
- the assignment of the inputs and outputs for the signal processing and
- the control mode.

Using a preset solution makes commissioning of the positioning controller much quicker and easier. By changing individual parameters, the preset solutions can be adapted to the needs of the specific task. Preset solutions modified in this way are stored in the device as user data sets. This helps you quickly achieve your desired motion solution.

4.3.1 Preset solutions

Preset solutions are complete parameter data sets which are provided to handle a wide variety of typical application movement tasks.

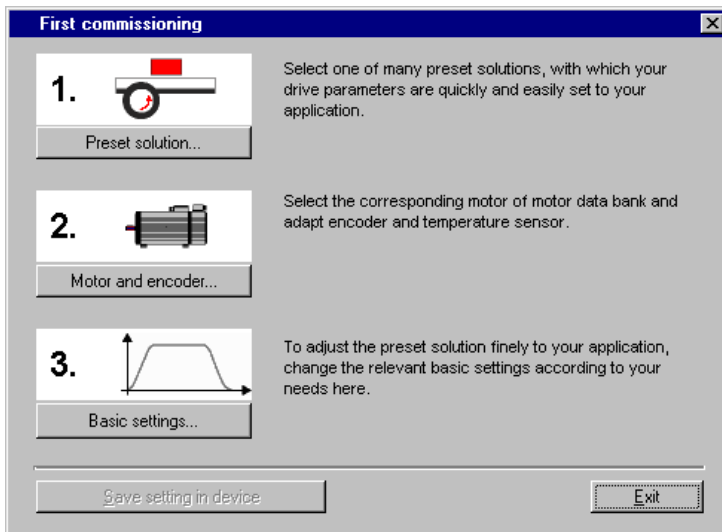

Figure 4.2 Initial commissioning

A total of 20 preset solutions covers the typical areas of application for speed control with the CDE/CDB3000 controller.

Abbreviation	Reference source	Start control via/ Bus control profile
TCT_1	+/-10 V-analog - torque	I/O terminals
SCT_1	+/-10 V-analog	I/O terminals
SCT_2	Fixed speed table	I/O terminals
SCC_2	Fixed speed table	CANopen field bus interface – EasyDrive profile “Basic”
SCB_2	Fixed speed table	Field bus option module (PROFIBUS) – EasyDrive-Profil „Basic”
SCC_3	CANopen field bus interface	CANopen field bus interface – EasyDrive profile “Basic”
SCB_3	Field bus option module (PROFIBUS)	CANopen field bus interface – EasyDrive profile “Basic”
SCP_3	PLC	PLC
SCT_4	PLC	I/O terminals
SCC_4	PLC	CANopen field bus interface – EasyDrive profile “ProgPos”
SCB_4	PLC	Field bus option module (PROFIBUS) – EasyDrive profile “ProgPos”
PCT_2	Tables driving set	E/A-Klemmen
PCC_2	Tables driving set	CANopen field bus interface – EasyDrive profile “TabPos”
PCB_2	Tables driving set	Field bus option module (PROFIBUS) – EasyDrive profile “TabPos”
PCC_1	CANopen field bus interface	CANopen field bus interface – CiA 402 Profile Position mode – CiA 402 Profile Velocity mode – CiA 402 Interpolated mode
PCB_1	Field bus option module (PROFIBUS)	Field bus option module (PROFIBUS) – EasyDrive profile “DirectPos”
PCP_1	PLC	PLC

Table 4.1 Preset solutions for speed control with CDE/CDB3000

Abbreviation	Reference source	Start control via/ Bus control profile
PCT_3	PLC	I/O terminals
PCC_3	PLC	CANopen field bus interface – EasyDrive profile “ProgPos”
PCB_3	PLC	Field bus option module (PROFIBUS) – EasyDrive profile “ProgPos”

Table 4.1 Preset solutions for speed control with CDE/CDB3000

All preset solutions have their own individual basic setting window in the DriveManager 3.x.

Procedure

- Select the preset solution matching your application..

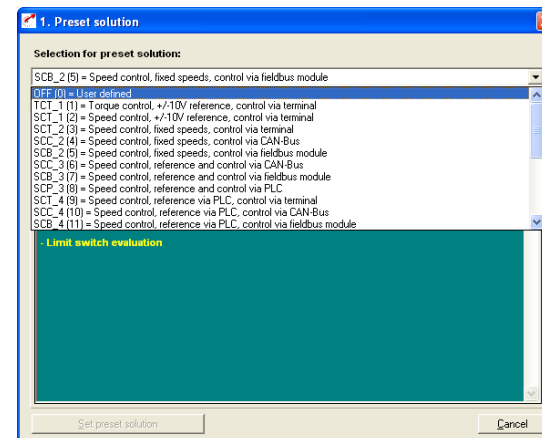

Figure 4.3 Selection of preset solution



NOTE: For detailed information on preset solutions and on terminal assignment refer to the CDE/CDB3000 Application Manual.

4.3.2 Setting the motor and encoder

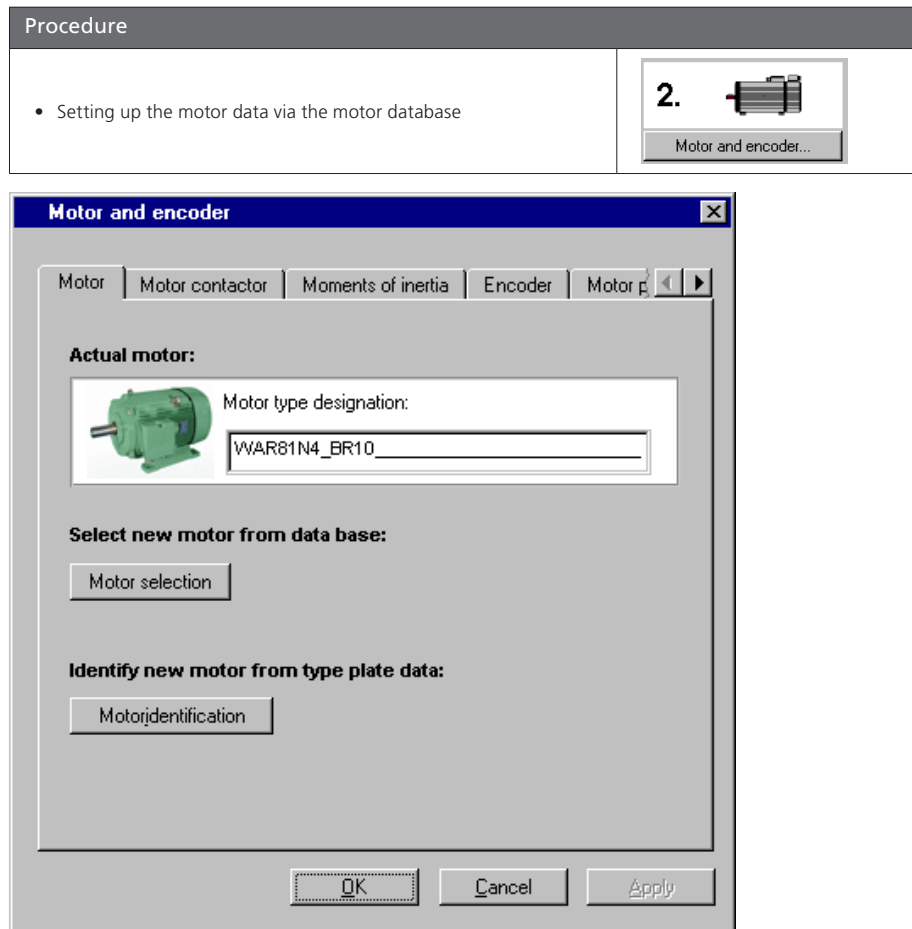

Figure 4.4 Motor and encoder setup

A database is available containing the settings for all motors. Using the correct motor data set ensures

- that the electrical parameters of the motor are correctly set,

- that the motor protection ("Motor protection" tab) is correctly set and
- that the control circuits of the drive are preset.



NOTE: The torque controller is set up optimally, so no further adjustments are necessary.

The setting of the speed controller is based on the assumption that the machine moment of inertia reduced onto the motor shaft is equal to the motor moment of inertia.

The speed and position controllers offer a high degree of damping, and so are also suitable for loop control of elastic mechanisms.

For special settings to optimize the speed and position control loops, please use the CDE/CDB3000 Application Manual.

Click on the "Motor selection" button on the "Motor" tab to select the right motor from your installed database. The motor type is indicated on its name plate. If the motor data set is supplied on a data carrier (floppy disk, CD-ROM), it can be loaded directly by clicking on the "Different Directory" button.

Setting of the encoder

The encoder connected to the motor is set up on the Encoder tab. It is also possible to work with two encoders. The first encoder is used for commutation and speed control of the motor (motor encoder) and the second for position control. Both functions can also be implemented with just one encoder.

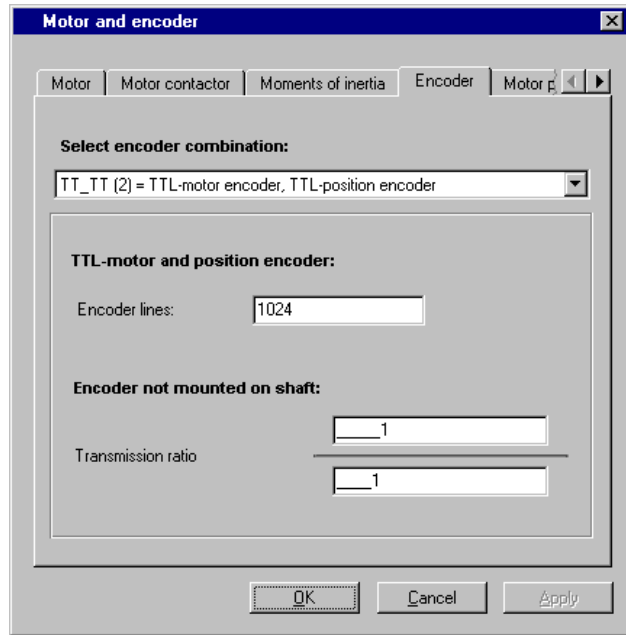

Every encoder combination has a special setup screen.

For more information on setting up the encoders, refer to the CDE/CDB3000 Application Manual.

Checking the encoder

To check the encoder the motor shaft is rotated by hand. The viewing angle when checking is from the front onto the shaft end (flange). The "Setpoint and actual values" status display, under "nist, Actual speed", must indicate a positive speed in clockwise rotation and a negative speed in counter-clockwise rotation. If the speed is incorrect, check the following points:

- Is the encoder cable correctly connected to the motor and the positioning controller?
- Is the encoder cable in use the correct one for the type of encoder?

4.3.3 Making basic settings

Custom setup screens are provided for fine adjustment of each preset solution. You can use them to adapt the drive to your application. For a detailed description of the individual functions, refer to the CDE/CDB3000 Application Manual.

Procedure

- Making basic settings

Basic settings...

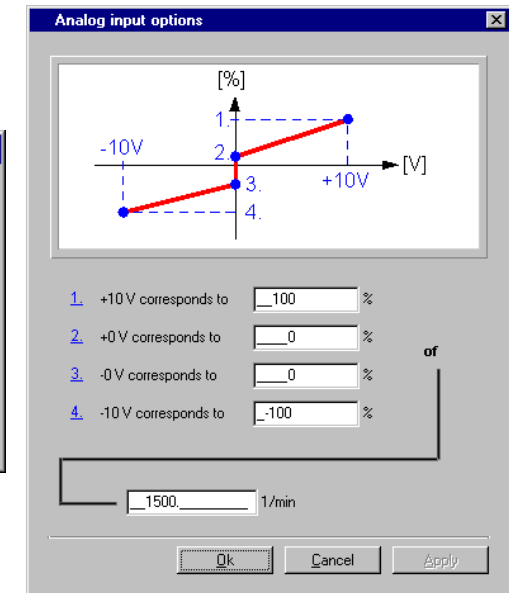
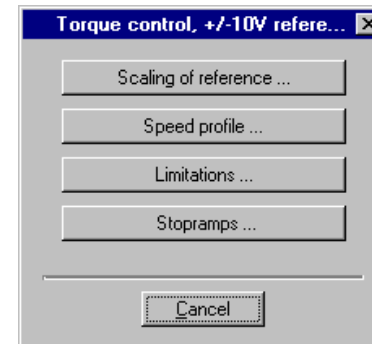

4.3.4 Saving the settings

Procedure		
DriveManager 3.x CDE/CDB3000 > Setup or: Active device > Change settings		Saving the settings in the device Any changes which are to be stored permanently in the device must be saved by way of the CDE/CDB3000 setup screen.

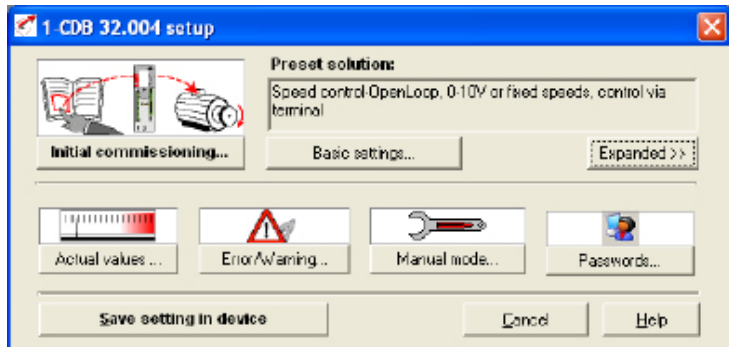

The changes made can also be saved to a file.

Procedure		
DriveManager 3.x CDE/CDB3000 Setup or: Active device > Save device settings to > file		Saving the settings to a file Choose the file name (e.g. mydata). All parameters are saved under the chosen file names (e.g. mydata) with the appropriate extension (*.00D). The device data can be assigned a description prior to saving.



Continue with "Test run", see section 4.4.

4.4 Test run

The drive is tested without the coupled mechanism. The test run is carried out in speed controlled mode, independently of the chosen preset solution.

A test run is still possible even if the motor is already coupled to the system:



ATTENTION:

Test run with installed motor:

In this case it must be ensured that the test does not damage the system! In particular, pay attention to positioning range limits.

Please note that you yourself are responsible for safe operation. LTi DRIVES GmbH cannot accept liability for any damage incurred.

Danger to life from uncontrolled rotation!

Before motors with a feather key at the shaft end are commissioned, the feather key should be secured against being ejected, if this cannot be prevented by drive elements such as pulleys, couplings, or the like.

Preset solution, torque control:

In this preset solution the drive must not be run without load torque, otherwise the motor shaft would accelerate uncontrolled up to the preset speed limit.



ATTENTION:

Destruction of the motor:

The motors are intended for operation on the positioning controller. Direct connection to the mains supply may destroy the motor.

High surface temperatures may occur on the motors. Temperature-sensitive items should therefore not be placed on top of or attached to the motors. Protective measures may be needed to prevent touching.

The temperature sensor installed in the coil is to be connected to the direct drive controller in order to prevent overheating of the motor by the temperature monitor.

The motor brake (if installed) should be checked for fault-free functioning before installation of the motor.

The optionally installed standstill holding brake is only designed for a limited number of emergency braking operations. Use as a working brake is prohibited.

1. **ENABLE SAFE STANDSTILL (ONLY CDE)**
High level at terminal X2/22
2. **SET ENPO POWER STAGE ENABLE**
High level at terminal X2/10

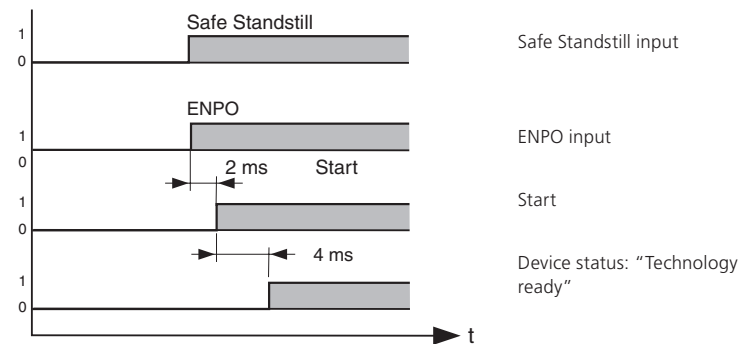

Pay attention to the time response of the inputs.

3. **CONTROL WITH DRIVEMANAGER 3.X:**
Select "Speed control" and start the drive, e.g. with setpoint 100 rpm.

Procedure	
DriveManager 3.x > Open-loop control	
or:	
Active device > Open-loop control > Basic operation modes	

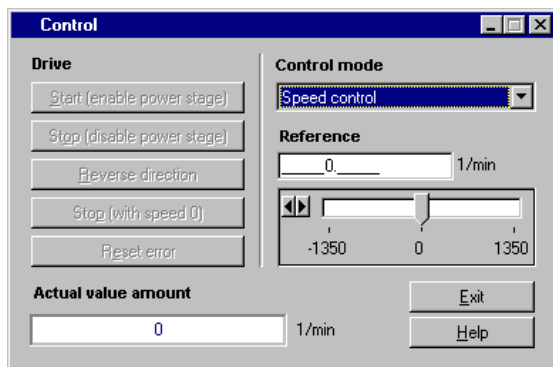

Procedure

DriveManager 3.x > Digital Scope

or:

Active device > Monitoring > Quickly changing digital scope values



Check the drive response

Now you can assess the drive response with the aid of step responses, which can be recorded using the DriveManager 3.x digital scope function

Select the following three recording variables:

- 0: Speed: Setpoint
- 1: Speed: Actual
- 2: Torque: Actual

Trigger condition:

Channel 0; rising edge, pretrigger 10 %; level: 30 rpm

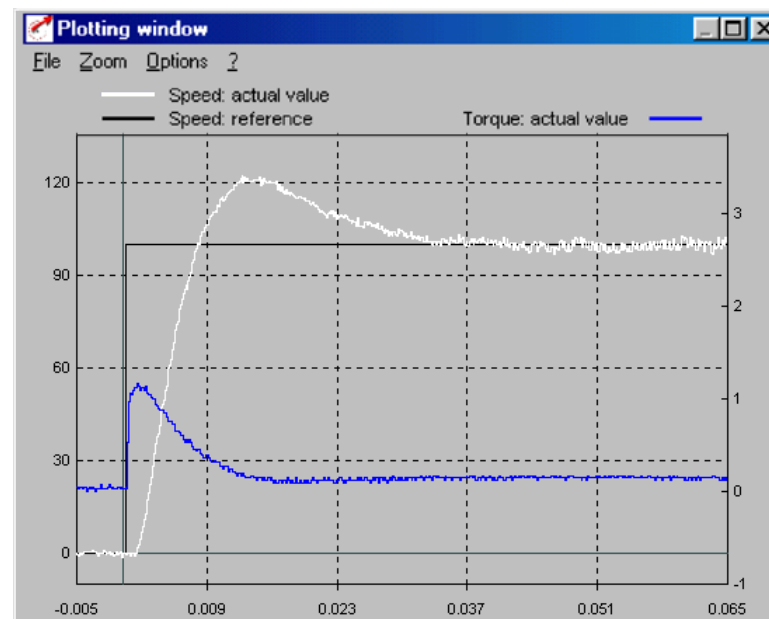

Start the drive with a setpoint value of 100 rpm for example.

Compare the step response of your drive with the diagram. With resolvers the overshoot of the actual speed should be around 20 %; with incremental encoders around 30 % (referred to the setpoint value). Make sure the drive system exhibits small signal response (the torque setpoint value must be less than the maximum).

If the torque setpoint reaches its maximum, reduce the speed step.

The time response (rise time, correction time) of the speed control loop is independent of the speed step.

Result:

If the step response of your drive more or less matches the diagram, you can be sure that the motor phases are correctly wired, the encoder is correctly connected, and the CDE/CDB3000 parameters are set to the correct motor.

If the step response deviates severely from the diagram, it is to be assumed that

- the motor data set was selected incorrectly, or
- the cabling is faulty.

Check the individual steps from chapter 3 “Electrical installation” and section 4.3 “Initial commissioning” and repeat the test run.

The step response may also deviate if the ratio of the machine moment of inertia reduced onto the motor shaft relative to the motor moment of inertia is very high. Here the loop control settings must be optimized. For special settings to optimize the speed and position control loops, please use the CDE/CDB3000 Application Manual.

4.5 Operation with KeyPad KP300

The KP 300 can be plugged directly into the positioning controller (X4). For details on individual functions and handling refer to the KP300 operation manual.

Overview KeyPad

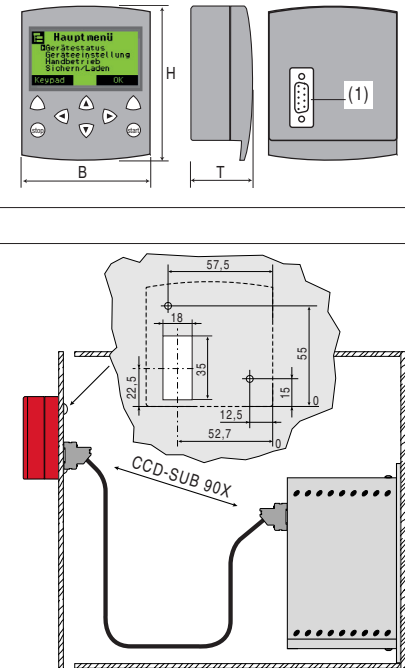
Designation	Summary explanation
KP300	KeyPad with graphical display (128 x 64 pixels) for parameter setting, actual value display and serial commissioning of positioning controllers. Graphical display including device status and parameter texts. Language: German or English (configurable). The KeyPad KP300 supports the SmartCard “SC-XL”.
KP300 mechanism	
Dimensions (see illustration)	70 x 84 x 37 mm (w x h x d)
Weight	120 g
Connection (RS232)	
Standard (1)	Can be plugged directly into drive unit
Installing the KP300	
<p>The unit can be installed directly on the drive controller or by way of a RS232 cable (e.g. CCD-SUB903) at any location inside the switch cabinet (see drawing).</p> <p>Please use only self-tapping screws for thermoplastics (e.g. EJOT PT screw, type K30 x 8 WN1412).</p> <p> Note: The KP300 has IP20 protection. As switch cabinets usually have IP44 protection or higher, the KP300 must not be operated outside of the cabinet without additional protective measures (such as a cut-out in the cabinet door).</p>	

4.6 Operation with DriveManager 3.x

Precondition:

- DriveManager 3.x user software version V3.4 or higher installed on the PC.

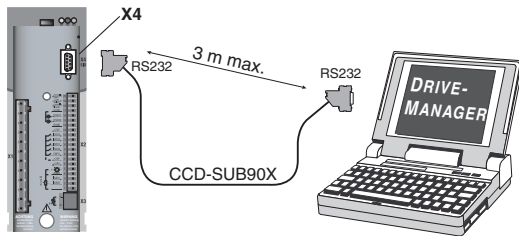

Figure 4.5 Positioning controller connection to PC/DriveManager 3.x

The key functions

Icon	Function	Menu
	Change setting of active device	Active device > Change settings
	Print parameter data set	Active device > Print settings
	Digital Scope	Active device > Monitoring > Quickly changing digital scope values
	Control drive	Active device > Open-loop control > Basic operation modes
	Connect to device	Communication > Connect > Single device
	Bus initialization, Change setting	Communication > Bus configuration
	Disconnect all devices	Communication > Disconnect

Icon	Function	Menu
	Save data set of active device to file	Active device > Save device settings to
	Data set transfer from file to active device	Active device > Load device settings from

5 Diagnosis/Troubleshooting

5.1 LEDs

At the top right of the positioning controller there are three status LEDs coloured red (H1), yellow (H2) and green (H3).

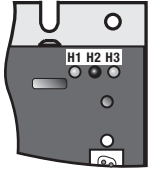
Device state	red LED (H1)	yellow LED (H2)	green LED (H3)	
Power on	-	-	●	
Ready (ENPO set)	○	●	●	
In service/Auto-tuning active	○	*	●	
Warning	●	● / *	●	
Error	* (flash code)	○	●	
○ LED off, ● LED on, * LED flashing				

5.2 Error messages

If an error occurs during operation it is indicated by a flash code from LED H1 (red) on the positioning controller. The code indicates the type of error. If a KP300 (previously KP200-XL) is connected, the KeyPad displays the error type as an abbreviated code.

Flash code of red LED H1	Display KeyPad	Explanation	Cause/Remedy
1x	E-CPU	Collective error	The exact error code can be read from the KeyPad or DriveManager 3.x.
2x	E-OFF	Undervoltage shut-off	Check power supply. Also occurs briefly in response to normal power-off.
3x	E-OC	Current overload shut-off	Short-circuit, ground fault: Check cabling of connections, check motor coil, check neutral conductor and grounding (see also section 3, Installation). Device setup not correct: Check parameters of control circuits. Check ramp setting.
4x	E-OV	Voltage overload shut-off	Voltage overload from mains: Check mains voltage. Restart device. Voltage overload resulting from feedback from motor (regenerative operation): Slow down braking ramps. If not possible, use a braking resistor.
5x	E-OLM	Motor protection shut-off	Motor overloaded (after I x t monitoring): Slow down process cycle rate if possible. Check motor dimensioning.
6x	E-OLI	Device safety shut-off	Device overloaded: Check dimensioning. Possibly use a larger device.
7x	E-OTM	Motor temperature too high	Motor PTC correctly connected? Parameter MOPTC correctly set(type of motor PTC evaluation)? Motor overloaded? Allow motor to cool down. Check dimensioning.
8x	E-OTI	Positioning controller overheated	Ambient temperature too high: Improve ventilation in cabinet. Load too high during driving/braking: Check dimensioning. Possibly use a braking resistor.

1) For more information see also CDE/CDB/CF3000 Application Manual

Table 5.1 Error messages

If you have any technical queries about project planning or commissioning of the drive unit, please contact our Helpline.

Helpline

You can reach us:

Mon.-Fr.: 8 a.m. - 5 p.m. Phone +49 6441/966-180
 mail: helpline@lt-i.com
 Fax: +49 6441/966-137

If you need further assistance, our specialists at the LTI Service Center will be happy to help.

Service repairs

You can reach us:

Mon.-Fr.: 8 a.m. - 5 p.m. Phone +49 6441/966-888
 mail: service@lt-i.com
 Fax: +49 6441/966-211



NOTE: If you need more detailed assistance and advice, you will find all the services we offer in the "Support & Service" order catalogue, available to download from the section of the same name on our website at www.lt-i.com.

5.3 User errors in Keypad operation

Error	Cause	Remedy
ATT1	Parameter cannot be changed at current user level or is not editable.	Select user level 1-MODE higher.
ATT2	Motor must not be controlled via the CTRL menu.	Cancel start signal from a different control location.
ATT3	Motor must not be controlled via the CTRL menu because of error state.	Reset error.
ATT4	New parameter value impermissible	Change value.
ATT5	New parameter value too high	Reduce value.
ATT6	New parameter value too low	Increase value.
ATT7	Card must not be read in current state.	Reset start signal.
ERROR	Invalid password	Enter correct password.

Table 5.2 Keypad user error: Reset with start/enter

5.4 User errors in SmartCard operation

Error	Cause	Remedy
ERR91	SmartCard write-protected	Use different SmartCard
ERR92	Error in plausibility check	
ERR93	SmartCard not readable, wrong positioning controller type	
ERR94	SmartCard not readable, parameter not compatible	
ERR96	Connection to SmartCard broken	
ERR97	SmartCard data invalid (checksum)	
ERR98	Insufficient memory on SmartCard	
ERR99	Selected area not present on SmartCard, no parameters transferred from SmartCard	

Table 5.3 SmartCard error: Reset with stop/return

5.5 Errors in power switching

Error	Cause	Remedy
Power on. Positioning controller shows no response (LEDs off).	In case of too frequent switching the unit protects itself by high-resistance isolation from the system.	After a rest phase of a few minutes the device is ready to start once again.

5.6 Reset

The reset function is divided into two areas with differing effects. Parameter reset restores to the last value stored in the device. Device reset restores the entire data set to the factory setting (delivery defaults).

Parameter reset with Keypad

If you are in the setup mode of a parameter and press the two cursor keys simultaneously, the parameter you are currently editing will be reset to the last setting stored (= saved with parameter 150-SAVE).

Factory setting with Keypad

Press both cursor keys simultaneously during positioning controller power-up to reset all parameters to their factory defaults and the system is reinitialized.

Factory setting with DriveManager 3.x

In the "Active device" menu, the "Reset to factory setting" option can be used to restore the delivery defaults of the device.

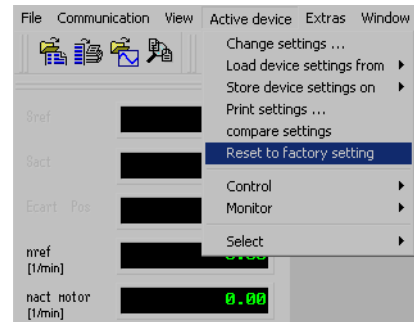

ATTENTION: The factory setting also resets the selected preset solution. Check the terminal assignment and functionality of the positioning controller in this operation mode, or load your own user data set.

A Appendix

A.1 Current capacity of positioning controllers

The maximum permissible positioning controller output current and the peak current are dependent on the mains voltage, the motor cable length, the power stage switching frequency and the ambient temperature. If the conditions change, the maximum permissible current capacity of the positioning controllers also changes - refer to the following characteristic lines and tables.

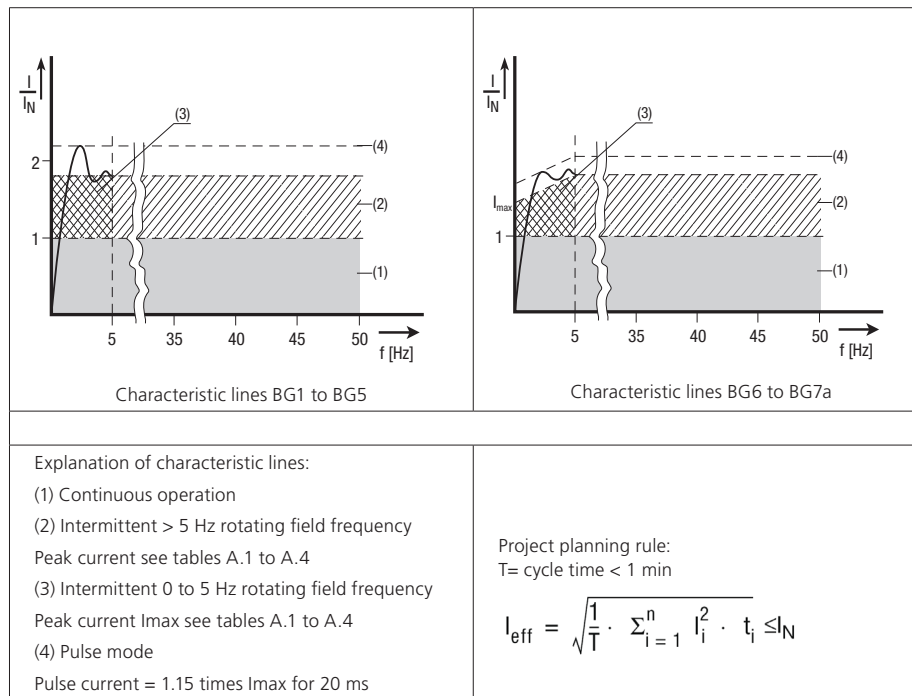

Positioning controllers for 230 V systems

Servo controllers	Switching frequency of power stage [kHz]	Ambient temperature [°C]	Rated current	Peak current [A _{eff}] ³⁾		
			at 230 V [A _{eff}]	for intermittent operation 0 to 5 Hz	for intermittent operation > 5 Hz	for time ⁴⁾ [s]
CDE/CDB 32.003,Cx.x	4	45	2.4	4.3	4.3	30
	8	40	2.4	4.3	4.3	
	12	40	2.1	3.75	3.75	
	16	40	1.8	3.2	3.2	
CDE/CDB 32.004,Cx.x ¹⁾	4	45	4	7.2	7.2	30
	8	40	4	7.2	7.2	
	12	40	3.5	5.7	6.3	
	16	40	3	5.0	5.4	
CDB 32.008,Cx.x ¹⁾ CDE/CDB 32.008,Wx.x	4	40	7.1	12.8	12.8	30
	8	40	7.1	12.8	12.8	
	12	40	6.3	10	11.35	
	16	40	5.5	8	9.9	

¹⁾ With heat sink HS3... or additional cooling surface
³⁾ For 230 V systems
⁴⁾ Shut-off as per I² x t characteristic

Motor cable length 10 m
 Mounting height 1,000 m above MSL
 End-to-end mounting

Table A.1 Positioning controllers for 230 V systems

Positioning controllers for 400/460 V systems, variant "W":

Servo controllers	Switching frequency of power stage [kHz]	Ambient temperature [°C]	Rated current		Peak current $[A_{eff}]^{3)}$			for time ⁴⁾ [s]
			at 400 V	at 460 V	at rotating field frequency rising in linear mode 0 to 5 Hz		for intermittent operation	
			$[A_{eff}]$	$[A_{eff}]$	0 Hz	5 Hz	> 5 Hz	
CDE/CDB 34.003,Cx.x (0.75 kW)	4	45	2.2	2.2	4	4	4 (1.8 I _N)	30
	8	40	2.2	2.2	4	4	4 (1.8 I _N)	
	12	40	1.6	1.6	2.9	2.9	2.9 (1.8 I _N)	
	16	40	1.0	1.0	1.8	1.8	1.8 (1.8 I _N)	
CDE/CDB 34.005,Wx.x (1.5 kW)	4	45	4.1	4.1	7.4	7.4	7.4 (1.8 I _N)	30
	8	40	4.1	3.6	7.4	7.4	7.4 (1.8 I _N)	
	12	40	3.2	2.4	5.7	5.7	5.7 (1.8 I _N)	
	16	40	2.4	1.8	4.3	4.3	4.3 (1.8 I _N)	
CDE/CDB 34.006,Wx.x (2.2 kW)	4	45	5.7	5.7	10.3	10.3	10.3 (1.8 I _N)	30
	8	40	5.7	5.7	10.3 ¹⁾ /7.8 ²⁾	10.3	10.3 (1.8 I _N)	
	12	40	4.15	3.1	7.5 ¹⁾ /6.4 ²⁾	7.5	7.5 (1.8 I _N)	
	16	40	2.6	1.9	4.7	4.7	4.7 (1.8 I _N)	
CDE/CDB 34.008,Wx.x (3 kW)	4	45	7.8	7.8	14	14	14 (1.8 I _N)	30
	8	40	7.8	7.8	14	14	14 (1.8 I _N)	
	12	40	6.4	4.8	11	11	11 (1.8 I _N)	
	16	40	5.0	3.7	7.8	9	9 (1.8 I _N)	
CDE/CDB 34.010,Wx.x (4 kW)	4	45	10	10	18	18	18 (1.8 I _N)	30
	8	40	10	8.8	18	18	18 (1.8 I _N)	
	12	40	8.1	6.0	13	14.5	14.5 (1.8 I _N)	
	16	40	6.2	4.6	7.8	11	11 (1.8 I _N)	
CDE 34.010, Wx.x,S	4	40	14	14	25	25	25	40
	8	40	14	12.2	25	25	25	
	12	40	10.3	7.7	13	14.5	14.5	
	16	40	6.6	4.9	7.8	11	11	

Table A.2 Positioning controllers for 400/460 V systems, variant "W"

Servo controllers	Switching frequency of power stage [kHz]	Ambient temperature [°C]	Rated current		Peak current $[A_{eff}]^{3)}$			for time ⁴⁾ [s]
			at 400 V	at 460 V	at rotating field frequency rising in linear mode 0 to 5 Hz		for intermittent operation	
			$[A_{eff}]$	$[A_{eff}]$	0 Hz	5 Hz	> 5 Hz	
CDE/CDB 34.014,Wx.x (5.5 kW)	4	45	14	14	25	25	25 (1.8 I _N)	30
	8	40	14	12.2	25	25	25 (1.8 I _N)	
	12	40	10.3	7.7	18	18	18 (1.8 I _N)	
	16	40	6.6	4.9	12	12	12 (1.8 I _N)	
CDE/CDB 34.017,Wx.x (7.5 kW)	4	45	17	17	31	31	31 (1.8 I _N)	30
	8	40	17	13.5	31	31	31 (1.8 I _N)	
	12	40	12.5	9.3	23	23	23 (1.8 I _N)	
	16	40	8.0	6.0	14	14	14 (1.8 I _N)	
CDE/CDB 34.024,Wx.x (11 kW)	4	45	24.0	24	43	43	43 (1.8 I _N)	30
	8	40	24.0	24	43	43	43 (1.8 I _N)	
	12	40	19.5	14	35	35	35 (1.8 I _N)	
	16	40	15	11	27	27	27 (1.8 I _N)	
CDE/CDB 34.032,Wx.x (15 kW)	4	45	32	32	58	58	58 (1.8 I _N)	30
	8	40	32	28	58	58	58 (1.8 I _N)	
	12	40	26	20	39	47	47 (1.8 I _N)	
	16	40	20	15	32	36	36 (1.8 I _N)	
1) = CDE 2) = CDB			3) for 400 V systems 4)) Shut-off as per I ² x t characteristic			Motor cable length 10 m Mounting height 1,000 m above MSL End-to-end mounting		

Table A.2 Positioning controllers for 400/460 V systems, variant "W"

Positioning controllers for 400/480 V systems, variant "W"

Servo controllers	Switching frequency of power stage [kHz]	Ambient temperature [°C]	Rated current		Peak current [A _{eff}] ³⁾			for time ⁴⁾ [s]
			at 400 V	at 480 V	at rotating field frequency rising in linear mode 0 to 5 Hz		for intermittent operation	
			[A _{eff}]	[A _{eff}]	0 Hz	5 Hz	> 5 Hz	
CDE 34.044,Wx.x (22 kW)	4	45	45	41	90	90	90 (2.0 I _N)	3 ⁵⁾ /10 ⁶⁾
	8	40	45	41	90	90	90 (2.0 I _N)	
	12	40	45	41	90	90	90 (2.0 I _N)	
	16	40	42	38	84	84	84 (2.0 I _N)	
CDE 34.058,Wx.x (30 kW)	4	45	60	54	120	120	120 (2.0 I _N)	3 ⁵⁾ /10 ⁶⁾
	8	40	60	54	120	120	120 (2.0 I _N)	
	12	40	58	52	116	116	116 (2.0 I _N)	
	16	40	42	38	84	84	84 (2.0 I _N)	
CDE 34.070,Wx.x (37 kW)	4	45	72	65	144	144	144 (2.0 I _N)	3 ⁵⁾ /10 ⁶⁾
	8	40	72	65	144	144	144 (2.0 I _N)	
	12	40	58	52	116	116	116 (2.0 I _N)	
	16	40	42	38	84	84	84 (2.0 I _N)	
CDB 34.044,Wx.x (22 kW)	4	45	45	41	68	67,5	67 (1.5 I _N)	30 ⁵⁾
	8	40	45	41	45	45	67 (1.5 I _N)	
	12	40	36	33	36	36	54 (1.5 I _N)	
	16	40	27	24	27	27	41 (1.5 I _N)	
CDB 34.070,Wx.x (37 kW)	4	45	72	65	108	108	108 (1.5 I _N)	30
	8	40	72	65	72	72	108 (1.5 I _N)	
	12	40	58	52	58	58	87 (1.5 I _N)	
	16	40	42	38	42	42	63 (1.5 I _N)	
CDE/CDB 34.088,Wx.x (47 kW)	4	45	90	81	170	180	180 (2.0 I _N)	30
	8	40	90	81	134	180	180 (2.0 I _N)	
	12	40	90	81	107	144	144 (1.6 I _N)	
	16	40	72	65	86	115	115 (1.6 I _N)	

Table A.3 Positioning controllers for 400/480 V systems, variant "W"

Servo controllers	Switching frequency of power stage [kHz]	Ambient temperature [°C]	Rated current		Peak current [A _{eff}] ³⁾			
			at 400 V	at 480 V	at rotating field frequency rising in linear mode 0 to 5 Hz		for intermittent operation	for time ⁴⁾ [s]
			[A _{eff}]	[A _{eff}]	0 Hz	5 Hz	> 5 Hz	
CDE/CDB 34.108,Wx.x (55 kW)	4	45	110	99	170	220	220 (2.0 I _N)	30
	8	40	110	99	134	165	165 (1.5 I _N)	
	12	40	90	81	107	144	144 (1.6 I _N)	
	16	40	72	65	86	115	115 (1.6 I _N)	
CDE/CDB 34.140,Wx.x (75 kW)	4	45	143	129	270	286	286 (2.0 I _N)	30
	8	40	143	129	215	215	215 (1.5 I _N)	
	12	40	115	104	172	172	172 (1.5 I _N)	
	16	40	92	83	138	138	138 (1.5 I _N)	
CDE/CDB 34.168,Wx.x (90 kW)	4	45	170	153	190	315	315 (1,9 I _N)	10
	8	40	170	153	151	220	220 (1.3 I _N)	
	12	40	136	122	121	164	164 (1.2 I _N)	
	16	40	109	98	97	131	131 (1.2 I _N)	

1) = CDE
 2) = CDB
 3) for 400 V systems
 4) Shut-off as per $I^2 \times t$ characteristic
 5) Under pre-load of max. 70%
 6) At heat sink temperature < 45 °C
 Motor cable length 10 m
 Mounting height 1,000 m above MSL
 End-to-end mounting

Table A.3 Positioning controllers for 400/480 V systems, variant "W"

Positioning controllers for 400/480 V systems, variant "L"

Servo controllers	Switching frequency of power stage [kHz]	Ambient temperature [°C]	Rated current		Peak current [A _{eff}] ³⁾			for time ⁴⁾ [s]
			at 400 V	at 480 V	at rotating field frequency rising in linear mode 0 to 5 Hz		for intermittent operation	
			[A _{eff}]	[A _{eff}]	0 Hz	5 Hz	> 5 Hz	
CDB.x4.044,L (22 kW)	4	45	45	41	67,5	67,5	67,5 (1.5 I _N)	60
	8	40	45	41	45	45	67,5 (1.5 I _N)	
	12	40	36	41	36	36	54 (1.5 I _N)	
	16	40	27	24	27	27	41 (1.5 I _N)	
CDE.x4.044,L (22 kW)	4	45	45	41	90	90	90 (2.0 I _N)	30
	8	40	45	41	90	90	90 (2.0 I _N)	
	12	40	45	41	90	90	90 (2.0 I _N)	
	16	40	42	38	84	84	84 (2.0 I _N)	
CDB.x4.058,L (30 kW)	4	45	60	54	90	90	90 (1.5 I _N)	60
	8	40	60	54	60	60	90 (1.5 I _N)	
	12	40	48	43	48	48	72 (1.5 I _N)	
	16	40	36	33	36	36	54 (1.5 I _N)	
CDE.x4.058,L (30 kW)	4	45	60	54	120	120	120 (2.0 I _N)	30
	8	40	60	54	120	120	120 (2.0 I _N)	
	12	40	58	52	116	116	116 (2.0 I _N)	
	16	40	42	38	84	84	84 (2.0 I _N)	
CDB.x4.070,L (37 kW)	4	45	72	65	108	108	108 (1.5 I _N)	60
	8	40	72	65	72	72	108 (1.5 I _N)	
	12	40	58	52	58	58	87 (1.5 I _N)	
	16	40	42	38	42	42	63 (1.5 I _N)	
CDE.x4.070,L (37 kW)	4	45	72	65	144	144	144 (2.0 I _N)	30
	8	40	72	65	144	144	144 (2.0 I _N)	
	12	40	58	52	116	116	116 (2.0 I _N)	
	16	40	42	38	84	84	84 (2.0 I _N)	

Table A.4 Positioning controllers for 400/480 V systems, variant "L"

Servo controllers	Switching frequency of power stage [kHz]	Ambient temperature [°C]	Rated current		Peak current [A _{eff}] ³⁾			for time ⁴⁾ [s]
			at 400 V	at 480 V	at rotating field frequency rising in linear mode 0 to 5 Hz		for intermittent operation	
			[A _{eff}]	[A _{eff}]	0 Hz	5 Hz	> 5 Hz	
CDB/CDE. x4.088,L (55 kW)	4	45	110	99	205	220	220 (2.0 I _N)	30
	8	45	110	99	165	187	187 (1.7 I _N)	
	12	45	110	99	132	165	165 (1.5 I _N)	
	16	45	90	81	106	135	135 (1.5 I _N)	
CDB/CDE. x4.108,L (75 kW)	4	45	143	129	230	286	286 (2.0 I _N)	30
	8	45	143	129	190	215	215 (1.5 I _N)	
	12	45	114	103	152	172	172 (1.5 I _N)	
	16	45	91	82	122	138	138 (1.5 I _N)	
CDB/CDE. x4.140,L (90 kW)	4	45	170	153	230	340	340 (2.0 I _N)	10
	8	45	170	153	190	255	255 (1.5 I _N)	
	12	45	136	122	152	204	204 (1.5 I _N)	
	16	45	109	98	122	163	163 (1.5 I _N)	
CDB/CDE. x4.168,L (110 kW)	4	45	210	189	230	340	340 (1.6 I _N)	10
	8	45	210	189	190	255	255 (1.2 I _N)	
	12	45	168	151	152	204	204 (1.2 I _N)	
	16	45	134	121	122	163	163 (1.2 I _N)	
CDB/CDE. x4.208,L (110 kW)	4	45	250	225	230	325	325 (1.3 I _N)	10
	8	45	250	225	190	255	255 (1.0 I _N)	
	12	45	168	151	152	204	204 (1.2 I _N)	
	16	45	134	121	122	163	163 (1.2 I _N)	

3) for 400 V systems

4) Shut-off as per I² x t characteristic

Motor cable length 10 m

Mounting height 1,000 m above MSL

End-to-end mounting

Table A.4 Positioning controllers for 400/480 V systems, variant "L"

A.2 Technical data

CDE/CDB32.004,C to CDE/CDB34.006,W

Designation	CDE/CDB32.003						CDE/CDB32.004						CDE/CDB32.008						CDE/CDB34.003						CDE/CDB34.005						CDE/CDB34.006					
	Technical data																																			
Output, motor side ¹⁾	BG1						BG2																													
Recommended rated power with 4-pole standard motor for CDB	0.375 kW		0.75 kW		1.5 kW		0.75 kW		1.5 kW		2.2 kW																									
Voltage	3 x 0 ... 230 V						3 x 0 ... 400/460 V																													
Continuous current effective (I _N)	2.4 A		4.3 A		7.1 A		2.2 A		4.1 A		5.7 A																									
Peak current	(see Table A.1)						(see Table A.2)																													
Rotating field frequency	0 ... 400 Hz																																			
Switching frequency of power stage	4, 8, 12, 16 kHz (factory setting 8 kHz)																																			
Input, mains side																																				
Mains voltage	1 x 230 V -20 % +15 %						3 x 400 V (-15%) ... 3 x 460 V (+10%)																													
Device connected load	1.0 kVA		1.6 kVA		3.0 kVA		1.5 kVA		3.0 kVA		4.2 kVA																									
Asymmetry of mains voltage	-						±3 % max.																													
Frequency	50/60 Hz ±10 %																																			
Power loss at CDE 4 kHz power stage clock frequency 8/16 kHz	49 W 52 W		63 W 70 W		110 W 120 W		90 W 97 W		95 W 127 W		121 W 163 W																									
Power loss at CDB 4 kHz power stage clock frequency 8/16 kHz	35 W 30 W		48 W 55 W		95 W 105 W		55 W 70 W		80 W 112 W		106 W 148 W																									
Braking chopper power electronics																																				
Peak braking power with int. braking resistor (only with variant CDE/CDB34 ..., Wx.x, BR)	-		-		1.7 kW at 360 Ω		-		1.6 kW at 360 Ω		1.6 kW at 360 Ω																									
Minimum ohmic resistance of an externally installed braking resistor	100 Ω						56 Ω						180 Ω																							

Table A.5 CDE/CDB32.004,C to CDE/CDB34.006,W

CDB34.008,W to CDB34.032,W

Designation	CDE/CDB34.008		CDE/CDB34.010		CDE34.010,W,S		CDE/CDB34.014		CDE/CDB34.017		CDE/CDB34.024		CDE/CDB34.032		
	Technical data														
Output, motor side ¹⁾	BG3				BG4				BG5						
Recommended rated power with 4-pole standard motor for CDB	3.0 kW		4.0 kW		-		5.5 kW		7.5 kW		11 kW		15 kW		
Voltage	3 x 0 ... 400/460 V														
Continuous current effective (I _N)	7.8 A		10 A		10 A		14 A		17 A		24 A		32 A		
Peak current	(see Table A.2)														
Rotating field frequency	0 ... 400 Hz														
Switching frequency of power stage	4, 8, 12, 16 kHz (factory setting 8 kHz)														
Input, mains side															
Mains voltage	3 x 400 V (-15%) ... 3 x 460 V (+10%)														
Device connected load	5.7 kVA		7.3 kVA		9.4 kVA		10.2 kVA		12.4 kVA		17.5 kVA		23.3 kVA		
Asymmetry	±3 % max.														
Frequency	50/60 Hz ±10 %														
Power loss at CDE 4 kHz power stage clock frequency 8/16 kHz	150 W 177 W		187 W 222 W		-		225 W 283 W		270 W 340 W		330 W 415 W		415 W 525 W		
Power loss at CDB 4 kHz power stage clock frequency 8/16 kHz	135 W 162 W		172 W 207 W		-		210 W 268 W		225 W 325 W		315 W 400 W		400 W 510 W		
Braking chopper power electronics															
Peak braking power with int. braking resistor (only with variant CDE/CDB34 ..., Wx.x, BR)	6.0 kW at 90 Ω				-				6.0 kW at 90 Ω				6.0 kW at 90 Ω		
Minimum ohmic resistance of an externally installed braking resistor	81 Ω				-				47 Ω				22 Ω		

1) Data apply: to 1-phase devices at 230V, to 3-phase devices at 400 V

Table A.6 CDB/CDE34.008 to CDB/CDE34.032

CDB/CDE34.044,W to CDB/CDE34.168,W

Technical data	Designation							
	CDE/CDB34.044	CDE/CDB34.058	CDE/CDB34.070	CDE/CDB34.088	CDE/CDB34.108	CDE/CDB34.140	CDE/CDB34.168	
Output, motor side ¹⁾	BG6			BG7			BG7a	
Recommended rated power with 2-pole standard motor for CDB	22 kW	30 kW	37 kW	47 kW	55 kW	75 kW	90 kW	
Voltage ²⁾	3 x 0 ... 400/480 V							
Continuous current effective (I _N)	45 A	60 A	72 A	90 A	110 A	143 A	170 A	
Peak current	(see Table A.3)							
Rotating field frequency	0 ... 400 Hz							
Switching frequency of power stage	4, 8, 12, 16 kHz (for CDE3000 factory setting 8 kHz) (for CDB3000 factory setting 4 kHz)							
Input, mains side								
Mains voltage	3 x 400 V (-15%) ... 3 x 480 V (+10%)							
Device connected load	31 kVA	42 kVA	50 kVA	62 kVA	76 kVA	99 kVA	118 kVA	
Asymmetry	±3 % max.							
Frequency	50/60 Hz ±10 %							
Power loss	CDB 610 W	700 W 830 W	860 W 1010 W	1050 W 1300 W	1300 W 1600 W	1700 W 2100 W	2000 W 2500 W	
Braking chopper power electronics								
Minimum ohmic resistance of an externally installed braking resistor	≥ 18		≥ 13	≥ 12	≥ 10	≥ 8.5	≥ 6.5	
1) Data apply: to 1-phase devices at 230V, to 3-phase devices at 400 V								
2) $3 \times U_{mains} \times 0,95$								

Table A.7 CDB/CDE34.044,W to CDB/CDE34.168,W

CDB/CDE 34.044,L to CDB/CDE 34.208,L

Technical data	Designation								
	CDE/CDB34.044,L	CDE/CDB34.058,L	CDE/CDB34.070,L	CDE/CDB34.088,L	CDE/CDB34.108,L	CDE/CDB34.140,L	CDE/CDB34.168,L	CDE/CDB34.208,L	
Output, motor side ¹⁾	BG6			BG7			BG7a		
Recommended rated power with 2-pole standard motor for CDB	22 kW	30 kW	37 kW	55 kW	75 kW	90 kW	110 kW	110 kW	
Voltage ²⁾	3 x 0 ... 400/480 V								
Continuous current effective (I _N)	45 A	60 A	72 A	110 A	143 A	170 A	210 A	250 A	
Peak current	(see Table A.4)								
Rotating field frequency	0 ... 400 Hz								
Switching frequency of power stage	4, 8, 12, 16 kHz (for CDE3000 and CDB3000 factory setting 4 kHz)								
Input, mains side									
Mains voltage	3 x 400 V (-15%) ... 3 x 480 V (+10%)								
Device connected load	31 kVA	42 kVA	50 kVA	76 kVA	99 kVA	118 kVA	128 kVA	128 kVA	
Asymmetry	±3 % max.								
Frequency	50/60 Hz ±10 %								
Power loss	CDB 610 W	830 W 1010 W	1010 W 1950 W	2300 W 2550 W	3000 W 3000 W				
Braking chopper power electronics									
Minimum ohmic resistance of an externally installed braking resistor	≥ 10 Ω			≥ 12 Ω	≥ 10 Ω	≥ 8.5 Ω	≥ 6.5 Ω	≥ 5 Ω	
1) Data apply: to 1-phase devices at 230V, to 3-phase devices at 400 V									
2) $3 \times U_{mains} \times 0,95$									

Table A.8 CDB/CDE 34.044,L to CDB/CDE 34.208,L

A.3 Environmental conditions - CDE/CDB3000

Characteristic		Positioning controller	Accessories (KeyPad KP300 UM-xxxx and CM-xxxx module)
Climatic conditions	in operation as per EN 61800-2, IEC 60721-3-3 class 3K3	+5 ... 40°C ²⁾ at relative humidity of 5 ... 85 % without condensation	0 ... 55°C ²⁾ at relative humidity of 5 ... 85 % without condensation
	in storage as per EN 61800-2, IEC 60721-3-1 class 1K3 and 1K4	-25 ... +55 °C ³⁾ at relative humidity of 5 ... 95 %	
	in transit as per EN 61800-2, IEC 60721-3-2 class 2K3	-25 ... +70 °C ⁴⁾ Relative humidity 95 % at max. +40°C	
Protection	Device	IP20 (terminals IP00)	
	Cooling method	Push-through heat sink IP54	Convection IP20
Touch protection		BGV 3	
Mounting height		to 1000 m above MSL, over 1000 m above MSL with power reduction, max. 2000 m above MSL	

Vibration limit in transit, as per EN 61800-2, IEC 60721-3-2 class 2M1

Frequency	Amplitude	Acceleration
2 < f < 9 Hz	3.5 mm	Not applicable
9 < f < 200 Hz	Not applicable	10 m/s ²
200 < f < 500 Hz	Not applicable	15 m/s ²

Shock limit in transit, as per EN 61800-2, IEC 60721-2-2 class 2M1

Drop height of packed device max. 0.25 m

Vibration limit of system⁵⁾, as per EN 61800-2, IEC 60721-3-3 class 3M1

Frequency	Amplitude	Acceleration
2 < f < 9 Hz	0.3 mm	Not applicable
9 < f < 200 Hz	Not applicable	1 m/s ²

2) The absolute humidity is limited to max. 25 g/m³. That means that the maximum values for temperature and relative air humidity stipulated in the table must not occur simultaneously.

3) The absolute humidity is limited to max. 29 g/m³. So the maximum values for temperature and relative air humidity stipulated in the table must not occur simultaneously.

4) The absolute humidity is limited to max. 60 g/m³. This means, at 70°C for example, that the humidity may only be max. 40%.

5) The devices are only designed for stationary use.

A.4 Using a line reactor

Line reactors are required:

- where the positioning controller is used in applications with disturbance variables corresponding to environment class 3, as per EN 61000-2-4 and above (hostile industrial environment).
- where there is a DC link between multiple positioning controllers.

Characteristics of environment class 3 include:

- Mains voltage fluctuations > + 10 % UN
- Short-time interruptions between 10 ms and 60 s
- Voltage asymmetry > 3 %

Environment class 3 typically applies where:

- a major part of the load is supplied by power converters (dc choppers or soft-start equipment);
- welding machines are present;
- induction or arc furnaces are present;
- large motors are started frequently;
- loads fluctuate rapidly.

Explanatory notes on Table A.11	
Residential	Limit to EN 61800-3 (First Environment), restricted availability. Maximum permissible motor cable length at which the interference emission (>9 kHz) is below the permissible limits. Only 10/15 metres was checked in the measurements..
Industrial:	Limit to EN 61800-3 (Second Environment), restricted availability. Maximum permissible motor cable length at which the interference emission (>9 kHz) is below the permissible limits. Only 25 metres was checked in the measurements..
1)	The interference emission at 10 and/or 25 metres was above the limits stipulated by the standard. This does not mean, however, that the mains filter is not working, but merely that it is not working optimally across the full frequency band. To conform to the standard, therefore, an external mains filter must be used.
2)	To conform to the standard, an upstream line reactor (uK = 2 % or 4 %) must additionally be installed.
12 kHz power stage clock frequency	At 12 kHz power stage clock frequency external mains filters must be used, as no measurement results with an internal mains filter are available.
Measurement method:	The permissible length of the motor cable was determined according to the standard (stipulated measurement method).

Table A.12 Explanatory notes on Table A.11

A.6 UL-Certification

The description of all measures to maintain UL approbation is to be found in the document „UL-Certification“ (ID No: 0927.01B.X.xx).

Mains load (example)

	Without line reactor	With line reactor	Change
	4 kW positioning controller, line impedance 0.6 mH	4 kW positioning controller, line impedance 6 mH	Without line reactor compared to with line reactor
Voltage distortion (THD) ¹⁾	99 %	33 %	-67 %
Mains current amplitude	18.9 A	9.7 A	-48 %
Mains current effective	8.5 A	6.23 A	-27 %
Commutation notches referred to the mains voltage	28 V	8 V	-70%
Life of the DC link capacitors	Nominal life	2 to 3 times nominal life	+100 to 200 %

¹⁾ THD = Total Harmonic Distortion ($U_5 \dots U_{41}$)

Table A.9 Change in system load resulting from insertion of a line reactor with 4% short-circuit voltage based on the example of a 4 kW positioning controller CDB34.010

Mains voltage asymmetry (example)

	Without line reactor			With line reactor		
	4 kW positioning controller, line impedance 0.6 mH			4 kW positioning controller, line impedance 6 mH		
Asymmetry of mains voltage	0 %	+3 %	-3 %	0 %	+3 %	-3 %
Mains current amplitude	18.9 A	25.4 A	25.1 A	9.7 A	10.7 A	11 A
Mains current effective	8.5 A	10.5 A	10.2 A	6.2 A	6.7 A	6.8 A

Table A.10 Effect of the line reactor with asymmetrical mains voltage based on the example of a 4 kW positioning controller CDE/CDB34.010



RECOMMENDATION:

The example shows that the benefits of a line reactor with 4 % short-circuit voltage are multi-faceted. We therefore recommend that you use a line reactor as a matter of course.

A.5 Mains filters

For details on the subject of electromagnetic compatibility (EMC) refer to section 3.3.

Permissible motor cable length with internal RFI filter

Drive controller	4 kHz power stage clock frequency		8 kHz power stage clock frequency		16 kHz power stage clock frequency	
	With integral mains filter		With integral mains filter		With integral mains filter	
	Industrial	Residential	Industrial	Residential	Industrial	Residential
CDE/B32.003	1)	1)	20	10	25	10
CDE/B32.004	1)	1)	20	10	25	10
CDE/B32.006	25	10	20	10	25	10
CDE/B32.008	25	10	20	10	25	10
CDE/B34.003	10	10	25	10	1)	1)
CDE/B34.005	10	10	25	10	25	1)
CDE/B34.006	10	10	25	10	25	1)
CDE/B34.008	25	10	25	10	20	1)
CDE/B34.010	25	10	25	10	20	1)
CDE/B34.014	10	1)	25	10 ²⁾	20	1)
CDE/B34.017	10	1)	25	10 ²⁾	20	1)
CDE/B34.044	25	10	25	10	-	-
CDE/B34.058	25	10	25	10	-	-
CDE/B34.070	25	10	25	10	-	-

1), 2) see Table A.12

Table A.11 Permissible motor cable length with integral mains filter dependent on standard 61800-3

Index

A

Appendix	65
Assignment for HTL encoder connection to X2.....	42
Assignment of encoder interface X7	41

B

Brake driver X9	29
Braking resistor (RB) - CDE/CDB	46
Breakthrough for push-through heat sink.....	10

C

Cable cross-sections.....	74, 75
CAN interface - CDE/CDB	45
Check the drive response	57
Choice of commissioning	49
Cold plate.....	9
Commissioning	49
Connection brake resistor	46
Connection diagram - CDB3000	18, 19
Connection diagram - CDE3000	15
Connection example for ENMO.....	44
Connection of an external braking resistor	47
Connection of LTi motors.....	34
Connection of PTC.....	35
Connection of the motor on the CDB3000	42
Connection of third-party motors.....	35
Control connections - CDB3000.....	36
Control connections - CDE.....	27
Control terminals traction drive	39
Current capacity of positioning controllers	65

D

Date of manufacture.....	3
DC network - CDE/CDB3000	46
Diagnosis/Troubleshooting	61
Dimensional drawings.....	8, 13
Dimensional drawings: liquid cooling	13
Disabling electrical isolation	24
Documentation overview	3
Drive with two measurement systems	41

E

Effective EMC installation.....	21
Electrical installation.....	15
Electrical isolation method	23
Electrical isolation method/voltage supply	23
Electrical specification of the HTL encoder interface	41
EN61000-3-2	26
Encoder connection	32
Encoder connection - CDB3000	40
Encoder interface X7.....	33
Environmental conditions CDE/CDB	71
Environment class	26
Error messages.....	61
Errors in power switching.....	63
External mains filter	21

F

Factory setting	29
-----------------------	----

H

How to use this manual	3
HTL encoder supply.....	42

I	
ID no.	2
Initial commissioning.....	50, 51
Intended use.....	6
Interference on the analog input.....	24
Isolated switching in the motor cable.....	44
K	
Key to connection diagram.....	15, 18
Key to connection diagram - CDB3000.....	19
Key to connection diagram - CDE3000.....	16
L	
Layout of CDB3000.....	20
Layout of CDE3000.....	17
LEDs.....	61
Liquid cooling.....	12
M	
Mains connection - CDE/CDB.....	25
Mains filters.....	72
Mains voltage asymmetry.....	72
Main window for the various settings in the DriveManager.....	50
Making basic settings.....	54
Matching motor/encoder cable.....	30
Mechanical installation.....	7
Monitoring of the internal braking resistor.....	47
Motor and encoder setup.....	53
Motor connection on the CDB3000.....	42
Motor protection tab.....	36
Motor shutdown.....	43
Mounting clearances.....	7, 10, 12
Multi-motor operation.....	44
N	
Notes for operation.....	7
O	
Operation with DriveManager.....	59
Operation with KeyPad KP300.....	58
Overview of connections - CDB.....	18
Overview of connections - CDE.....	15
P	
Pictograms.....	4
Pictograms used.....	6
Pin assignment of serial interface X4.....	45
Pin assignment X4.....	45
Pin assignment X5.....	45
Pin assignment X6.....	32
Positioning controller connection to PC/DriveManager.....	59
Positioning controllers for 230 V systems.....	65
Positioning controllers for 400/460 V systems.....	66
Positioning controllers for 400/480 V systems L.....	68
Positioning controllers for 400/480 V systems W.....	67
Preset solutions.....	51, 52
Project planning and function description.....	46
Project planning and installation rules.....	22
Protective conductor connection - CDE/CDB.....	22
R	
Ready made-up encoder cable.....	31
Reset.....	63
Responsibility.....	6

S

Safe Torque Off (STO)	47
Safety	5
Saving the settings.....	55
Selection of preset solution	52
Serial commissioning.....	49
Serial commissioning with DriveManager	49
Serial interface	45
Setting of the encoder	53
Setting the motor and encoder	53
Sizes	2
Specification of control connections - CDB3000.....	37
Specification of control connections - CDE	28
Specification of encoder interface X7	40
Star configuration layout of the protective conductor.....	22
STO	47
Supplying the HTL encoder	42
Switching in the motor cable	43

T

Technical data.....	31, 69
Test run.....	56
Trigger condition.....	57

U

UL approbation.....	73
Use of the analog inputs as digital inputs.....	23
User errors in KeyPad operation	62
User errors in SmartCard operation	62
Using a line reactor	71

W

Wall mounting.....	7
--------------------	---

X

X5	34, 43
X6	34
X7	34



LTI DRIVES GMBH

Gewerbestr. 5-9
35633 Lahnau
Germany
Phone +49 (0) 6441/ 96 6-0
Fax+49 (0) 6441/ 96 6-137

Heinrich-Hertz-Strasse 18
59423 Unna
Germany
Phone +49 (0) 2303/ 77 9-0
Fax +49 (0) 2303/ 77 9-397

www.lt-i.com
info@lt-i.com

WE RESERVE THE RIGHT TO MAKE TECHNICAL CHANGES.

The content of our documentation was compiled with the greatest care and attention, and based on the latest information available to us.

We should nevertheless point out that this document cannot always be updated in line with ongoing technical developments in our products.

Information and specifications may be subject to change at any time. For information on the latest version please refer to <http://drives.lt-i.com>

ID no.: 1001.20B.9-00

Date: 08/2013